



**ROMANIA**

**JOINT CONVENTION  
ON THE SAFETY OF SPENT  
FUEL MANAGEMENT  
AND  
ON THE SAFETY OF RADIOACTIVE WASTE  
MANAGEMENT**

**ROMANIAN  
THE SIXTH NATIONAL REPORT**

**2017**

CONTENT

<b>LIST OF ABBREVIATIONS AND SELECTED TERMS.....</b>	<b>6</b>
<b>LIST OF FIGURES .....</b>	<b>7</b>
<b>CONTRIBUTORS TO THE REPORT .....</b>	<b>8</b>
<b>SECTION A. INTRODUCTION.....</b>	<b>9</b>
<i>A1. Objectives.....</i>	9
<i>A2. Structure of the report.....</i>	9
<i>A3. Overall situation .....</i>	9
<i>A4. Summary of developments since the last review meeting .....</i>	13
<i>A4.1 Overview matrix.....</i>	13
<i>A4.2 Legislative and regulatory framework.....</i>	14
<i>A4.3 Regulatory review and licensing.....</i>	14
<i>A4.4 Spent fuel and radioactive waste management policy and strategy.....</i>	15
<i>A4.5 Significant achievements.....</i>	15
<i>A4.6 International peer reviews .....</i>	15
<i>A4.7 Progress on issues identified in the 5th review meeting .....</i>	17
<b>SECTION B. POLICIES AND PRACTICES (Article 32) .....</b>	<b>20</b>
<i>B1. Spent fuel and radioactive waste management policy.....</i>	20
<i>B2. Spent fuel and radioactive waste management practices .....</i>	22
<i>B2.1 Spent fuel practices .....</i>	22
<i>B2.1.1. Spent fuel from NPP.....</i>	22
<i>B2.1.2. Spent fuel from the research reactors .....</i>	25
<i>B2.1.2.1 ICN Pitesti .....</i>	25
<i>B2.1.2.2 IFIN-HH .....</i>	26
<i>B2.2. Radioactive waste management practices.....</i>	26
<i>B2.2.1. Management of radioactive waste from NPP .....</i>	26
<i>B2.2.2. Radioactive waste from nuclear fuel fabrication .....</i>	29
<i>B2.2.3 Management of non-fuel cycle radioactive waste .....</i>	30
<i>B2.2.3.1. Management of non-fuel cycle radioactive waste at IFIN-HH .....</i>	30
<i>B2.2.3.2. Disposal of radioactive waste.....</i>	31
<i>B2.2.3.3 Management of own radioactive waste at ICN Pitesti .....</i>	34
<i>B2.2.4. Radioactive waste from uranium mining and milling .....</i>	36
<i>B2.2.5. Decommissioning .....</i>	38
<i>B3. Criteria to define and categorize radioactive waste.....</i>	38
<b>SECTION C. SCOPE OF APPLICATION (Article 3) .....</b>	<b>40</b>
<b>SECTION D. INVENTORIES AND LISTS (Article 32) .....</b>	<b>41</b>
<i>D1. List of Spent Fuel Management Facilities.....</i>	41
<i>D2. Spent Fuel Inventory .....</i>	41
<i>D3. List of Radioactive Waste Management Facilities.....</i>	41
<i>D4. Radioactive Waste Inventory.....</i>	41
<b>SECTION E. LEGISLATIVE AND REGULATORY SYSTEM .....</b>	<b>42</b>
<i>E1. Implementing measures (Article 18).....</i>	42
<i>E2. Legislative and regulatory framework (Article 19).....</i>	42
<i>E2.1. Establishing and maintaining of legislative and regulatory framework.....</i>	42
<i>E2.2. Provisions of legislative and regulatory framework.....</i>	43
<i>E3. Regulatory authority in nuclear field (Article 20).....</i>	48
<i>E3.1. Responsibilities of National Commission for Nuclear Activities Control (CNCAN) .....</i>	48
<i>E3.2 Position of CNCAN in the Government Structure.....</i>	50
<i>E3.3 CNCAN Organisational Structure and Human and Financial Resources.....</i>	50

<i>E4. Other Governmental Authorities .....</i>	<i>53</i>
<i>E5. Cooperation with other governmental authorities.....</i>	<i>55</i>
<i>E6. Independence of Regulatory Authority in nuclear field.....</i>	<i>55</i>
<b>SECTION F. OTHER GENERAL SAFETY PROVISIONS .....</b>	<b>56</b>
<i>F1. Responsibility of the license holder (Article 21).....</i>	<i>56</i>
<i>F2. Human and financial resources (Article 22) .....</i>	<i>57</i>
<i>F2.1. Qualified staff availability as needed for safety related activities during the operating lifetime of a spent fuel and radioactive waste management facility.....</i>	<i>57</i>
<i>F2.2. Financial resources for operation of spent fuel and radioactive waste management facilities.....</i>	<i>60</i>
<i>F2.3. Financial provision for institutional controls and monitoring arrangements after closure of disposal facility.....</i>	<i>61</i>
<i>F3. Quality assurance (Article 23).....</i>	<i>61</i>
<i>F4. Operational radiation protection (Article 24).....</i>	<i>62</i>
<i>F4.1. Exposures of workers and public .....</i>	<i>62</i>
<i>F4.1.1. Optimization of exposures.....</i>	<i>62</i>
<i>F4.1.2. Exposure limits .....</i>	<i>64</i>
<i>F4.1.3. Control of releases.....</i>	<i>64</i>
<i>F4.2. Discharges.....</i>	<i>64</i>
<i>F4.2.1. Optimization of discharges .....</i>	<i>64</i>
<i>F4.2.2. Limitation of doses in normal operation.....</i>	<i>64</i>
<i>F4.3. Uncontrolled releases and mitigation of consequences of unplanned and uncontrolled releases.....</i>	<i>64</i>
<i>F5. Emergency preparedness (Article 25) .....</i>	<i>65</i>
<i>F5.1. Legal requirements for on-site and off-site emergency preparedness .....</i>	<i>65</i>
<i>F5.2. Planning for radiation emergencies in the vicinity of Romanian territory.....</i>	<i>66</i>
<i>F5.3. The implementation of emergency preparedness measures .....</i>	<i>67</i>
<i>F6. Decommissioning (Article 26).....</i>	<i>68</i>
<i>F6.1. General Requirements related to decommissioning.....</i>	<i>68</i>
<i>F6.2. Fulfilment of the requirements of article 26 of Joint Convention .....</i>	<i>69</i>
<i>F6.2.1. Qualified staff and adequate financial resources .....</i>	<i>69</i>
<i>F6.2.2. Operational radiation protection, discharges, unplanned and uncontrolled releases .....</i>	<i>69</i>
<i>F6.2.3. Emergency preparedness.....</i>	<i>70</i>
<i>F6.2.4. Records of decommissioning operations.....</i>	<i>70</i>
<i>F6.3. Design requirements related to decommissioning .....</i>	<i>70</i>
<i>F6.4. NPP decommissioning plan .....</i>	<i>71</i>
<i>F6.5. Status of VVR-S research reactor decommissioning.....</i>	<i>72</i>
<i>G1. General safety requirements (Article 4).....</i>	<i>73</i>
<i>G1.1. Criticality and removal of heat.....</i>	<i>73</i>
<i>G1.2. Minimization of waste.....</i>	<i>73</i>
<i>G1.3. Interdependencies among different management steps .....</i>	<i>73</i>
<i>G1.4. Effective protection of individuals, society and environment .....</i>	<i>73</i>
<i>G1.5. Biological, chemical and other hazards .....</i>	<i>74</i>
<i>G1.6. Impact on future generations.....</i>	<i>74</i>
<i>G1.7. Avoidance of undue burdens on future generations .....</i>	<i>74</i>
<i>G2. Existing facilities (Article 5).....</i>	<i>74</i>
<i>G2.1. Review of the safety of the spent fuel management facilities of CNE Cernavoda.....</i>	<i>74</i>
<i>G2.2. Spent Fuel Bay and dry storage of spent fuel elements and fragments at ICN Pitesti .....</i>	<i>75</i>
<i>G3. Siting of proposed facilities (Article 6) .....</i>	<i>76</i>
<i>G3.1. Procedures for safety evaluation, public information and neighbour countries consultancy ..</i>	<i>76</i>
<i>G3.1.1. Site related factors likely to affect the safety of the facility .....</i>	<i>76</i>
<i>G3.1.2. Safety impact of the facility on individuals, society and environment.....</i>	<i>77</i>
<i>G3.1.3. Public consultation.....</i>	<i>77</i>
<i>G3.1.4. Consultation of Contracting Parties in the vicinity of the spent fuel management facilities .....</i>	<i>77</i>

G3.2. Avoidance of unacceptable effects on Contracting Parties in the vicinity of the spent fuel management facilities .....	77
G4. Design and construction of facilities (Article 7) .....	78
G4.1. Construction of Spent Fuel Handling and Storage Systems at CNE Cernavoda Unit 2.....	78
G4.2. Construction of Cernavoda Interim Spent Fuel Dry Storage Facility (including handling systems).....	78
G5. Assessment of safety of facility (Article 8) .....	80
G5.1. Initial safety assessment.....	80
G5.2. Updated and detailed safety assessment.....	80
G6. Operation of facilities (Article 9) .....	81
G6.1. Licensing.....	81
G6.2. Operational limits and conditions .....	81
G6.3. Operation, maintenance, monitoring, inspection and testing .....	82
G6.4. Engineering and technical support.....	82
G6.5. Incidents reporting to CNCAN .....	82
G6.6. Collection and analysing of relevant operating experience .....	82
G6.7. Decommissioning plans for spent fuel management facilities .....	83
G7. Disposal of spent fuel (Article 10).....	83
<b>SECTION H. SAFETY OF RADIOACTIVE WASTE MANAGEMENT ....</b>	<b>85</b>
H1. General safety requirements (Article 11).....	85
H1.1. Control of criticality and heat generation .....	85
H1.2. Minimization of waste.....	85
H1.3. Interdependencies among different management steps .....	85
H1.4. Effective protection of workers, public and environment .....	85
H1.5. Biological, chemical and other hazards .....	86
H1.6. Impact on future generations.....	86
H1.7. Avoidance of undue burdens on future generations .....	86
H2. Existing facilities and past practices (Article 12) .....	87
H2.1. Safety of radioactive waste management.....	87
H2.2. Past practices.....	89
H3. Siting of proposed facilities (Article 13) .....	90
H3.1. Procedures for safety evaluation, public information and neighbour countries consultancy ..	90
H3.1.1. Site related factors likely to affect the safety of the facility.....	90
H3.1.2. Public consultancy.....	91
H3.1.3 Consultancy of Contracting Parties in the vicinity of the radioactive waste management facilities .....	92
H3.2 Avoidance of unacceptable effects on Contracting Parties in the vicinity of the radioactive waste management facilities .....	92
H4. Design and construction of facilities (Article 14) .....	92
H5. Assessment of safety of facilities (Article 15).....	93
H5.1. Assessment of safety of future disposal facility.....	93
H5.2. Updated and detailed safety assessment.....	94
H5.3. Assessment of safety of DNDR Baita Bihor repository.....	94
H6. Operation of facilities (Article 16).....	95
H6.1. Licensing.....	95
H6.2. Operational limits and conditions .....	95
H6.3. Operation, maintenance, monitoring, inspection and testing.....	96
H6.4. Engineering and technical support.....	96
H6.5. Procedures for characterization and segregation of radioactive waste.....	96
H6.6. Incidents reporting to CNCAN .....	97
H6.7 Collection and analyzing of relevant operating experience .....	97
H6.8 Decommissioning plans for radioactive waste management facilities .....	98
H6.9. Plans for closure of disposal facilities.....	98

<i>H7. Institutional measures after closure (Article 17)</i> .....	99
<b>SECTION I. TRANSBOUNDARY MOVEMENT (Article 27)</b> .....	<b>100</b>
<i>I1. Steps to transboundary movements</i> .....	100
<i>I1.1 Licensing of transboundary movement</i> .....	100
<i>I1.2. Subject of transit to relevant international obligations</i> .....	100
<i>I1.3. Consent of transboundary movement by the State of destination</i> .....	101
<i>I1.4. Licensing of transboundary movement</i> .....	101
<i>I1.5. Re-entry into the Romanian territory</i> .....	101
<i>I2. Shipment of spent fuel or radioactive waste to a destination south to latitude 60° south for storage or disposal</i> .....	101
<i>I3. Rights of contracting parties</i> .....	102
<b>SECTION J. DISUSED SEALED SOURCES (Article 28)</b> .....	<b>103</b>
<i>J1. Safe possession, remanufacturing or disposal of disused sealed sources</i> .....	103
<i>J2. Re-entry into the Romanian territory of disused sealed sources</i> .....	103
<b>SECTION K. PLANNED ACTIVITIES TO IMPROVE SAFETY OF SPENT FUEL AND RADIOACTIVE WASTE MANAGEMENT</b> .....	<b>104</b>
<b>SECTION L. ANNEXES</b> .....	<b>105</b>
<i>Annex L-1: List of Spent Fuel Management Facilities</i> .....	105
<i>Annex L-2: Inventory of spent fuel in storage at the end of 2016</i> <b>Error! Bookmark not defined.</b>	
<i>Annex L-3: List of Radioactive Waste Management Facilities</i> .....	106
<i>Annex L-4: Inventory of radioactive waste in storage at the end of 2016</i> <b>Error! Bookmark not defined.</b>	
<i>Annex L-5: Inventory of radioactive waste in disposal at the end of 2016</i> <b>Error! Bookmark not defined.</b>	
<i>Annex L-6: List of regulations</i> .....	108

## LIST OF ABBREVIATIONS AND SELECTED TERMS

ADR, AND, RID, ICAO, IMDG	<i>International agreements and convention for transport of dangerous goods</i>
AECL	<i>Atomic Energy of Canada Limited</i>
ANDR	<i>Nuclear Agency and for Radioactive Waste</i>
ANDRAD	<i>National Agency for Radioactive Waste (before ANDR)</i>
AN	<i>Nuclear Agency (before ANDR)</i>
CANDU	<i>CANada Deuterium Uranium</i>
CNCAN	<i>National Commission for Nuclear Activities Control</i>
CNE Cernavoda	<i>Cernavoda Nuclear Power Plant</i>
CNU	<i>Uranium National Company</i>
COG	<i>CANDU Owner Group</i>
DELs	<i>Derived Emissions Limits</i>
DFU	<i>Spent Filters Storage</i>
DICA	<i>Interim Dry Spent Fuel Storage Facility</i>
DIDR	<i>Solid Radioactive Waste Interim Storage Facility</i>
DNDR Baita Bihor	<i>National Repository for Low and Intermediate Level Radioactive Waste - SL Baita – Bihor</i>
EIA	<i>Environmental Impact Assessment</i>
ERC	<i>Emergency Response Centre</i>
EU	<i>European Union</i>
FCN	<i>Nuclear Fuel Plant Pitesti</i>
GO no. 11/2003	<i>Governmental Ordinance no. 11/2003 regarding the management of nuclear spent fuel and radioactive waste, including their disposal, with subsequent modifications and completions</i>
GO no. 7/2003	<i>Governmental Ordinance no. 7/2003 regarding the use of nuclear energy in exclusive peaceful purposes, with subsequent modifications and completions</i>
HEU Fuel	<i>Highly Enriched Uranium Fuel</i>
HLW	<i>High Level Waste</i>
IAEA	<i>International Atomic Energy Agency</i>
ICN Pitesti	<i>Institute for Nuclear Research (subsidiary of the State Owned Company Technologies for Nuclear Energy)</i>
ICSI Rm. Valcea	<i>National Institute for Research &amp; Development for Cryogenic and Isotopic Technologies Rm. Valcea</i>
IFIN-HH	<i>National Institute for Research and Development in Physics and Nuclear Engineering-Horia Hulubei</i>
ISCIR	<i>National Authority for Pressured Vessels and Hoisting Equipment</i>
JRTR	<i>Job Related Training Requirements</i>
Law no. 111/1996	<i>Law no. 111/1996 on the safe deployment, regulation, licensing and control of nuclear activities, republished</i>
LILW	<i>Low and Intermediate Level Waste</i>
LILW-SL	<i>Low and Intermediate Level Waste - Short Lived</i>
LILW-LL	<i>Low and Intermediate Level Waste – Long Lived</i>
LEU Fuel	<i>Low Enriched Uranium Fuel</i>
LEPI	<i>Post Irradiation Examination Laboratory</i>
MAI	<i>Ministry of Internal Affairs</i>

MCI	<i>Ministry of Research and Innovation</i>
NPP	<i>Nuclear Power Plant</i>
SAT	<i>Systematic Approach to Training</i>
RATEN	<i>State Owned Company Technologies for Nuclear Energy</i>
CITON	<i>Center of Technology and Engineering for Nuclear Projects</i>
SEA	<i>Strategic Environmental Assessment</i>
SGG	<i>General Secretariat of the Government</i>
SNN	<i>National Company "Nuclearelectrica"</i>
SSR	<i>Steady State Reactor</i>
STDR Pitesti	<i>Radioactive Waste Treatment Plant which belongs to ICN Pitesti</i>
STDR Magurele	<i>Radioactive Waste Treatment Plant which belongs to IFIN-HH</i>
TQI	<i>Training Qualification Index</i>
QMS	<i>Quality Management System</i>
WAC	<i>Waste Acceptance Criteria</i>
WANO	<i>World Association of Nuclear Operators</i>
WENRA	<i>Western European Nuclear Regulators Association</i>

## LIST OF FIGURES

<b>Figure A1</b>	Main organizations in the nuclear field in Romania	12
<b>Figure B1</b>	The National Strategy on Medium and Long Term Management of Spent Nuclear Fuel and Radioactive Waste	17
<b>Figure B2</b>	Romanian map – Location of the main organizations involved in radioactive waste and spent nuclear fuel management	19
<b>Figure B3</b>	DICA	21
<b>Figure B4</b>	The Storage Pits at LEPI for Irradiated Experimental Fuel Rods and Fragments	22
<b>Figure B5</b>	DIDR- outside view	24
<b>Figure B6</b>	DIDR- The structure no. 1 – warehouse inside view	25
<b>Figure B7</b>	IFIN-HH Radioactive waste management scheme	26
<b>Figure B8</b>	Disposal Galleries at DNDR Baita Bihor	28
<b>Figure B9</b>	ICN Pitesti Radioactive waste management scheme	29
<b>Figure E1</b>	Regulatory system pyramid	37
<b>Figure E2</b>	The organizational chart of CNCAN	42
<b>Figure F1</b>	The National System for the Management of Nuclear and Radiological Emergencies	55
<b>Figure H1</b>	A general view of the repository structures	80

## CONTRIBUTORS TO THE REPORT

This report is produced by **National Commission for Nuclear Activities Control** on behalf of Romania [www.cncan.ro](http://www.cncan.ro)

Contributions to the report were also made by:

- ✓ Nuclear Agency and for Radioactive Waste [www.agentianucleara.ro](http://www.agentianucleara.ro)
- ✓ Cernavoda Nuclear Power Plant [www.cne.ro](http://www.cne.ro)
- ✓ Institute for Nuclear Research (subsidiary of the State Owned Company Technologies for Nuclear Energy) [www.nuclear.ro](http://www.nuclear.ro)
- ✓ National Institute for Research and Development in Physics and Nuclear Engineering-Horia Hulubei [www.nipne.ro](http://www.nipne.ro)
- ✓ Uranium National Company [www.cnu.ro](http://www.cnu.ro)
- ✓ SC Conversmin SA [www.conversmin.ro](http://www.conversmin.ro)



## **SECTION A. INTRODUCTION**

### ***A1. Objectives***

Romania has ratified by the Law no. 105 / 1999 the Joint Convention on the safe management of spent fuel and on the safe management of radioactive waste.

By ratifying the Joint Convention on the safe management of spent fuel and on the safe management of radioactive waste, Romania has shown its willingness to undertake all the necessary steps for achieving the required level in the safe managing of the spent fuel and radioactive waste.

The report presents the situation of spent fuel and radioactive waste management activities in Romania, showing the existing situation, the safety issues of concern and the future actions to address these issues. The inventories of spent nuclear fuel and radioactive waste are as reported at 31 December 2016.

The conclusions of the report show that the spent fuel as well as the radioactive waste are safely managed in Romania. However, there are some planned activities in order to improve the safety of spent fuel management and the safety of radioactive waste management, which are summarized in Section K of this report.

The National Commission for Nuclear Activities Control, as the Romanian regulatory authority in nuclear field, will continue to monitor closely the solving of the issues of concern identified in this report.

### ***A2. Structure of the report***

The report follows closely the structure recommended in the document INFCIRC/604/Rev.2-“Guidelines regarding the Form and Structure of National Reports”. More detailed information is provided in the Annexes.

### ***A3. Overall situation***

Romania has one nuclear power plant, CNE Cernavoda, initially approved with five PHWR - CANDU-6 Canadian type reactors with a 705 MW(e) gross capacity each, in different implementation stages. Unit 1 and 2 are in commercial operation since December 1996, respectively November 2007. The electricity annually generated by CNE Cernavoda Units 1 and 2 represents approximately 18% of the overall electricity production of Romania, leading to approximately 5400 tHM to be unloaded during 30 years of operation. Units 3 and 4 are under preservation, since 1992. Recently construction of Unit 5 was definitively abandoned.

The legal representative of the nuclear power production sector in Romania is National Company “Nuclearelectrica” (SNN). SNN is a government owned company reporting to the Ministry of Energy. The company has its Headquarters in Bucharest and two subsidiaries:

- CNE Cernavoda, the operator of Cernavoda NPP – Units 1 and 2;
- Nuclear Fuel Plant in Pitesti (FCN).

In the late of 1970's, Romania choose CANDU type reactor for its first nuclear power plant. The main reasons of the choice were the high safety features of this technology and the possibility to manufacture in Romania the nuclear fuel and the heavy water as well as part of the equipment for this type of NPP.

Till 2016 the entire capacity of nuclear fuel was produced in Romania. Since 2016 the uranium powder of  $UO_2$  is imported from Cameco Port Hope Conversion Facility (PHCF). A part of  $UO_2$  is produced in Feldioara Sinterable Powder Plant in  $UO_2$  by recycling of nuclear material from FCN.

The fabrication of the CANDU nuclear fuel started in 1980, through the commissioning of a CANDU type Fuel Pilot Plant operating as a department of the Institute for Nuclear Research Pitesti (ICN Pitesti). In 1994, AECL and Zircotec Precision Industries Inc. Canada qualified the Nuclear Fuel Plant (FCN) Pitesti as a CANDU 6 fuel manufacturer. The plant has a current production of 225 tons uranium per year, respectively about 46 bundles per day. It supplies the necessary fuel for the operation of CNE Cernavoda Unit 1 and Unit 2.

After 6 years of cooling in the cooling pools of the reactors, the spent nuclear fuel is stored for 50 years in the Dry Storage Facility (DICA) located on the CNE Cernavoda site. The radioactive waste originated from operation of CNE Cernavoda Unit 1 and Unit 2 is stored into the storage facility on site.

Romania has one research reactor in operation, TRIGA research reactor, which belongs to the State Owned Company Technologies for Nuclear Energy (RATEN) through its subsidiary, Institute for Nuclear Research Pitesti (ICN).

RATEN is a Romanian legal entity under the authority of the Ministry of Energy, that is organized and acts as a national strategic state owned company, following the juridical rules of this type of organization and accordingly to the normative acts governing the research activities in the nuclear field. RATEN is founded with the aim to provide technical support for the nuclear power activities and to maintain and develop the technical competence during the life-time of the nuclear installations. RATEN participates in the national strategy development and in the achievement with priority of the scientific and technical objectives of the national programs in nuclear field approved by the Government.

RATEN was established in 2013, October 1st, by partial division of the Romanian Authority for Nuclear Activities Drobeta Turnu Severin, RAAN, after the separation of the research and development activities, technological engineering and technical support for nuclear power.

The entity has two subsidiaries:

- Institute for Nuclear Research Pitesti, RATEN-ICN, headquartered in Mioveni;
- Center of Technology and Engineering for Nuclear Projects Bucharest Magurele, RATEN-CITON, headquartered in Bucharest-Magurele.

It is intended that the spent nuclear fuel from TRIGA research reactor will be returned in the origin country. The radioactive waste resulted from operation of TRIGA research reactor as well as from operation of the research facilities on site are managed into the Radioactive Waste Treatment Plant (STDR Pitesti). The LILW-LL produced on site as well as the high activity

spent radioactive sources collected from all around the country are stored into the Post Irradiation Examination Facility (LEPI).

In Romania there is a VVR-S research reactor located in Magurele owned by National Institute for Research and Development in Physics and Nuclear Engineering-Horia Hulubei (IFIN-HH), which is under the coordination of the Ministry of Research and Innovation. After more than 40 years of operation, the VVR-S research reactor is now under decommissioning. The entire inventory of spent nuclear fuel consisting of type C-36 and EK10 was shipped back in the origin country, in Russian Federation. The radioactive wastes resulted from the decommissioning of VVR-S research reactor or from activities performed on the site, as well as the non-fuel cycle radioactive waste collected from all around the country are managed by the Radioactive Waste Treatment Plant (STDR Magurele), which is part of IFIN-HH Radioactive Waste Management Department.

In the NW part of the country, at Baita Bihor, is located a near surface repository, in geological formations, which is also owned by the National Institute for Research and Development in Physics and Nuclear Engineering-Horia Hulubei (IFIN-HH) and is licensed for disposal of non-fuel cycle radioactive waste. According to the waste acceptance criteria of the repository LILW – SL and limited activities of LILW-LL are disposed at Baita Bihor repository.

The main organizations involved in nuclear field are presented in Figure A1.

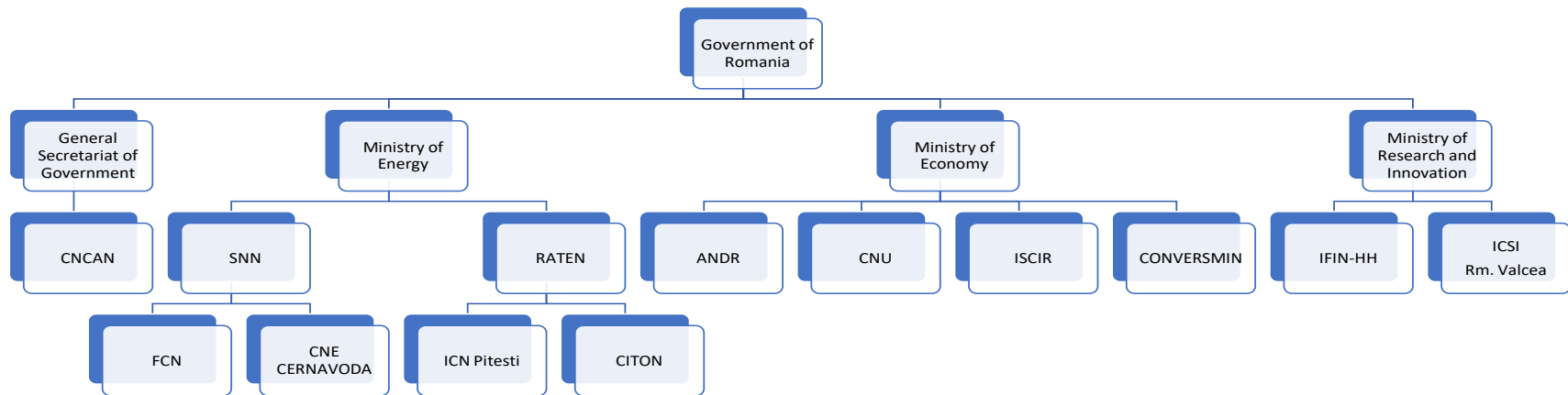

**Fig. A1 Main Organizations in Nuclear Field**

#### A4. Summary of developments since the last review meeting

##### A4.1 Overview matrix

In order to provide continuity from the sixth review meeting, the rapporteur's matrix has been revised and supplemented with references to explanatory sections of the report in the table below:

Type of Liability	Long Term Management Policy	Funding of Liabilities	Current Practices/Facilities	Planned Facilities
Spent Fuel	NPP •No reprocessing •Storage for 50 y •Deep geological disposal  RRs •Return to the origin countries (TRIGA) <i>B1, G1</i>	NPP •Contribution to the disposal fund  RRs •State budget	NPP •wet storage •dry storage  RRs •wet storage •return to the origin countries <i>B2.1.1, B2.1.2, G2, G6</i>	Deep geological repository (2065)       <i>G3, G4, G7</i>
Nuclear Fuel Cycle Waste	•Near surface disposal (SL) •Deep geological disposal (LL) U – disposal <i>B2.2.1, B2.2.2, H2.1</i>	•Contribution to the disposal fund •State budget	•Treatment and conditioning for storage •Storage on site   <i>B2.2.4</i>	Near surface repository (2023) Deep geological repository (2065) - LL
Non Nuclear Fuel Cycle Waste	Near surface disposal (SL) Deep geological disposal (LL)  <i>B2.2.3, H2.1</i>	•Licensee pays •State budget	•Treatment, conditioning and - storage on site •Near surface disposal <i>B2.2.3, H6</i>	Deep geological repository (2065) - LL
Decommissioning Liabilities	NPP, RRs -Immediate dismantling    <i>F6</i>	NPP •Contribution to the decommissioning fund RRs •State budget <i>F6</i>	NPP Initial decomm. plan RR TRIGA Revised decomm. plan RR VVR-S Decomm Phase 3 <i>B2.2.5, F6</i>	Deep geological repository (2065) - LL
Disused Radioactive Sources	•Return to producer •Storage/disposal <i>B1, J1</i>	Licensee pays   <i>J1</i>	•Return to producer •Storage/disposal  <i>J1</i>	Deep geological repository (2065) - LL <i>J1</i>

## **A4.2 Legislative and regulatory framework**

In order to meet the requirements of COUNCIL DIRECTIVE 2011/70/EURATOM of 19 July 2011 establishing a Community framework for the responsible and safe management of spent fuel and radioactive waste, CNCAN as nuclear regulatory authority of Romania developed new regulations and revised the existing regulations in the field of predisposal and disposal of radioactive waste, decommissioning of nuclear and radiological facilities as well as natural sources. (*More details in E2.2*)

In order to meet the requirements of Council Directive 2014/87/EURATOM from 06 July 2014, establishing a common European framework for nuclear safety CNCAN developed new fundamental regulation on nuclear safety for nuclear facilities (CNCAN Order No. 114/2017 - NSN 21)

The improvement of regulatory framework has been done in the framework of the Project “Regional Excellence Project on Regulatory Capacity Building in Nuclear and Radiological Safety, Emergency Preparedness and Response in Romania “. The objective of the project was to enhance the capabilities of the Romanian nuclear regulatory authority CNCAN in eight specific functional areas of work through exchange of experiences, best practices, and capacity building with the Norwegian Radiation Protection Authority and the International Atomic Energy Agency.

One of the specific areas of this project refers to “Enhancement of CNCAN capabilities for radioactive waste, spent nuclear fuel management, and decommissioning activities”. In this project CNCAN developed safety and licensing requirements for predisposal and disposal of radioactive waste, disused sources and spent nuclear fuel, safety and licensing requirements for decommissioning of nuclear and radiological facilities.

Also, in the framework of the above mentioned project the transport of radioactive materials regulations has been developed or updated.

A regulation containing licensing requirements for transport of radioactive materials details the activities and packages and materials which need license from CNCAN. The regulation listed the documents which need to be submitted to CNCAN in support of license application.

A guide on the content and format of the radiation protection program in transport as well as a guide containing the format and content of the package design safety assessment have been developed.

## **A 4.3 Regulatory review and licensing**

The improvement of regulatory framework has been done in the framework of the Project “Regional Excellence Project on Regulatory Capacity Building in Nuclear and Radiological Safety, Emergency Preparedness and Response in Romania“. In the framework of this project CNCAN developed methodologies and procedures for regulatory review of license applications and associated supporting documents. (*More details in E2.2*)

#### **A4.4 Spent fuel and radioactive waste management policy and strategy**

In order to fulfill the requirements of the Council Directive 2011/70/Euratom on the responsible and safe management of spent fuel and radioactive waste ANDR has prepared and submitted to the EC the Romanian National Programme for spent fuel and radioactive waste management.

The National Strategy on Medium and Long Term on the Management of Spent Nuclear Fuel and Radioactive Waste has been prepared by ANDR and now it is subjected to Strategic Environmental Assessment procedure.

#### **A4.5 Significant achievements**

The management of the spent nuclear fuel generated by CNE Cernavoda was improved by commissioning of the eighth MACSTOR 200 type concrete module. Also the design of an improved MACSTOR 400 module has been completed, assuring double capacity for spent fuel storage. For MACSTOR 400 design obtaining of the Environmental Agreement is in progress currently.

Significant achievements have been made in the management of radioactive waste arising from CNE Cernavoda by continuous performing the radioactive waste characterization works in a fully equipped laboratory having the capacity to perform both destructive and non-destructive analyses. The laboratory meets the requirements of ISO 17025 and it is working as notified laboratory. Starting with 2010, the total quantity of 77810.7 kg of combustible waste has been characterized and shipped, in few shipments, to STUDVIK, ( now Cyclife Sweden AB) in Sweden, for treatment by incineration and 11683.1 kg of metal waste has been shipped in one shipment to Cyclife Sweden AB in Sweden for melting.

The conceptual decommissioning plan for CNE Cernavoda Unit 1 and Unit 2 has been prepared and submitted to CNCAN. This plan will be revised for compliance with the new issued CNCAN Order No. 115 / 2017: Safety Regulation on decommissioning of nuclear and radiological installations.

#### **A4.6 International peer reviews**

##### *International peer review at CNCAN*

Upon the request of the Romanian Nuclear Authorities, an Integrated Regulatory Review Service (IRRS) (follow-up mission of IRRT and RaSIA) has been conducted at the National Commission for Nuclear Activities Control, in 2006, from 16 to 26 January, by an IAEA team of ten experts. The purpose of the mission was to review the effectiveness of the regulatory body of Romania and to exchange information and experience in the regulation of nuclear, radiation, radioactive waste and transport safety. The mission had two particular objectives: the first one related to the review of the progress in implementing recommendations or suggestions resulting from previous missions: International Regulatory Review Team - IRRT (May, 2002) and Radiation Safety Infrastructure Appraisal – RaSIA (May, 2004) and the second one was to provide further reviews in areas where significant changes have been reported since the previous missions. This mission was the first follow-up mission integrating both IRRT and RaSIA content using the IRRS

concept. It has demonstrated full compliance with the IRRT and RaSIA content and provided a more comprehensive review of the national regulatory infrastructure for nuclear, radiation, radioactive waste and transport safety.

A follow-up of this mission has been conducted in 2011, from 17 to 28 January. The purpose of this IRRS mission was to review the framework for regulating safety of nuclear facilities and activities and radioactive sources in Romania and the effectiveness of regulatory functions implemented by CNCAN and other authorities. The aim of the review was to compare the national regulatory framework with the requirements in the IAEA Safety Standard GSR Part 1, issued in 2010. The review was carried out by comparison against IAEA safety standards – IAEA Safety Fundamentals and Safety Requirements and Safety Guides – and the Codes of Conduct on the Safety and Security of Radioactive Sources and on the Safety of Research Reactors as the international benchmark for safety. The mission was also used to exchange information and experience between the IRRS review team members and the Romanian counterparts in the areas covered by IRRS.

The IRRS Review Team carried out the review of CNCAN and other authorities in all relevant areas: responsibilities and functions of the Government; global safety regime; responsibilities and functions of the regulatory body; the management system of the regulatory body, the activities of the regulatory body including the authorization, review and assessment, inspection and enforcement processes; development of regulations and guides; emergency preparedness and response; transport of radioactive materials safety; and the interface between safety and security.

The IRRS review addressed facilities and activities regulated by CNCAN, including the operation of nuclear power plants, research reactors, fuel cycle facilities, industrial, medical and research facilities, and waste management facilities. The review also addressed implementation of the Codes of Conduct on Safety and Security of Radioactive Sources and on the Safety of Research Reactors.

To help assess the effectiveness of the regulatory system, the mission included observations of inspection activities at a variety of nuclear and radiological facilities, covering the key activities regulated by CNCAN. In addition, four policy issues were addressed and discussed with CNCAN management and staff: Independence of the Regulatory Body; Openness, Transparency and Public Communication, Regulatory Approach, and Human Resources and Knowledge Management.

CNCAN provided the IRRS Team with initial documentation as advanced reference material including the results of its self-assessment. Additionally, the team took into account recommendations from the previous IRRS mission conducted in January 2006.

In several areas of regulatory responsibility, CNCAN has made significant progress from the previous IRRS mission. Additionally, the team highlighted the following:

- A comprehensive legal infrastructure that addresses all relevant international conventions and obligations is in place. In addition, the regulatory framework establishes CNCAN as the sole competent authority with the necessary powers to effectively implement its regulatory obligations.
- CNCAN staff demonstrated a high level of competence and dedication. This should be regarded as a valuable asset for maintaining nuclear and radiation safety in Romania.
- CNCAN conducts its activities with its stakeholders in an open and transparent manner.
- CNCAN properly coordinates and integrates safety and security matters.



A number of areas where improvements are necessary or desirable to enhance the effectiveness of Romania's regulatory performance in accordance with IAEA Safety Standards were identified. The following key issues should be addressed:

- Completion by the Government of the development and implementation of the national policies and strategies for the nuclear sector.
- Provision by the Government of adequate financial and human resources to CNCAN so it can discharge its regulatory responsibilities.
- Provision by the Government of greater flexibility for CNCAN to manage its own organizational structure and resources.
- Consistent implementation by CNCAN of the graded approach in its regulatory activities.

In addition, CNCAN should address, as a matter of priority, the following issues:

- Complete the review and revisions of regulations, as necessary
- Development and implementation of its integrated management system.

The follow-up mission, to review the implementation of the recommendations from 2011 has been carried-out during 9-16 October 2017.

#### *International review missions at CNE Cernavoda*

Cernavoda NPP processes and practices are systematically evaluated through international missions - every 2-3 years a WANO Peer Review is organized and the findings are addressed to improve performance. No area for improvement has been identified related to fuel/ waste management. The station focus on reducing the volume of waste has been recognized by WANO as a strength: "Innovative technology applications and a station wide commitment to reduce radioactive waste generation have resulted in a substantial reduction in waste burial volume and in waste generation, as well as a significant cost savings".

Also, in November 2016 CNE Cernavoda hosted an IAEA OSART Mission, which evaluated all station processes versus IAEA standards. This mission also did not identify any issue related to fuel/ waste management.

#### *International review mission at FCN Pitesti*

In the period 19-30.11.2011, at the FCN headquarters in Pitesti, the SEDO mission of IAEA (Safety Evaluation During Operation) was carried out. The SEDO mission was the second in the world at a nuclear fuel fabrication plant and it was carried out by a group of IAEA experts, at the request of the Romanian Government. A preliminary visit at FCN was conducted in September 2010. A follow up SEDO mission took place in the period 23-27.11.2015 and a final report was issued by IAEA experts.

### **A4.7 Progress on issues identified in the 5th review meeting**

The status of the issues identified in the 5<sup>th</sup> review meeting is presented below:

Issue	Responsible organization	Status
-------	--------------------------	--------

Ensuring sufficient and qualified staff in CNCAN commensurate with its safety-related activities.	Romanian Government	Ongoing challenge CNCAN has performed an analysis and requested the identified resources for the necessary staff.
Development of a preliminary programme for establishing a geological repository.	ANDR	Ongoing challenge
Getting the siting license for the new near-surface LILW repository.	ANDR	Ongoing challenge ANDR is now working to get the necessary agreements and approvals in order to apply for siting licence. The first phase of the future LILW-SL repository (DFDSMA) is planned to be opened in 2023
Revision of the financial contribution of the waste generators to the two funds earmarked for radioactive waste management and decommissioning activities.	ANDR	Ongoing challenge The revision of financial contribution is planned to be done in the next years. For the time being, studies have been performed in order to update the costs for the disposal facilities and for the decommission activities.
Improvement of regulatory framework for predisposal and disposal of radioactive waste, and for the decommissioning of nuclear and radiological facilities.	CNCAN	Completed The regulations on safety requirements for predisposal, disposal and decommissioning have been developed and they are published in the Official Bulletin of Romania.
Elaboration of the National Program for management of radioactive waste and spent fuel in accordance with the Council Directive 2011/70/EURATOM.	ANDR	The National Program for spent nuclear fuel and radioactive waste has been prepared according to the 2011/70/EURATOM Directive requirements and it has been submitted to EC in August 2015.
Decommissioning of the VVR-S research reactor.	IFIN-HH	Progress according to plan. The detailed decommissioning plan for the final phase of decommissioning was approved by CNCAN in 2016.
Identification of techniques for treatment and conditioning of RW which is to be disposed of in the Saligny repository.	ANDR/CNE Cernavoda	Ongoing challenge
Closure of the first part of Cetatuia II tailing pond of the Uranium Milling Plant (of the Feldioara Subsidiary	CNU	Ongoing challenge

of the Uranium National Company).		
Rehabilitation of the sites with sterile rock and low radioactive rock dumps resulted from geological research and mining activities for uranium ores production.	S.C. Conversmin S.A. /CNU	Ongoing challenge.

## **SECTION B. POLICIES AND PRACTICES** (*Article 32*)

### ***B1. Spent fuel and radioactive waste management policy***

For the time being, according to the existing National Strategy on Medium and Long Term on the Management of Spent Nuclear Fuel and Radioactive Waste including Disposal and Decommissioning of Nuclear and Radiological facilities, issued in 2004, Romania decided to use the CANDU nuclear fuel in open cycle, considering the spent nuclear fuel as HLW.

The legislative and regulatory policies that govern radioactive waste management in Romania implicitly include spent fuel management. As a result, legislation and policies on managing radioactive waste apply equally to spent fuel and radioactive waste, as they are valid for all forms of radioactive waste.

The objective of Romanian radioactive waste management policy is to ensure safe management of spent nuclear fuel and radioactive waste.

The main general aspects of radioactive waste management policy are presented below:

- The radioactive waste management, including the transport, shall be licensed, and shall be performed according to the provisions of the applicable laws and regulations, ensuring safety of facilities, protection of human health and environment;
- The licensees have the responsibility for the management of radioactive waste arising from operation and decommissioning of their own nuclear and radiological facilities, up to disposal. They shall bear the expenses related to the collection, handling, transport, treatment, conditioning, storage and disposal of the waste that they have produced;
- Romania adopts an open fuel cycle and consequently spent fuel from power reactors is not recycled and is planned to be disposed as a waste ;
- Spent fuel produced by NPP's shall be stored for limited period in dry storage facilities; after the interim storage period,
  - The spent nuclear fuel shall be disposed in a deep geological repository;
  - LILW-SL shall be disposed in near-surface facilities;
  - VLLW could be disposed in less complex arrangement than LILW-SL;
  - LILW-LL shall be disposed in a future deep geological repository;
- The import, export and intra-Community transfer of radioactive wastes is prohibited, subject to the following exemptions:
  - a. spent fuel from research reactors will be returned to the country of origin, under agreement;
  - b. the transfer of disused sealed sources, which must be returned to the supplier or manufacturer;
  - c. the transfer of radioactive waste for treatment or spent fuel for processing, with subsequent return of the waste product for final disposal;
  - d. the transfer of radioactive waste or spent fuel to another country for final disposal but only when the receiving country has the technical and administrative capability to meet international standards.
- The generation of radioactive waste is to be kept to the minimum practicable level in terms of activity and volume through appropriate design measures, facility operation and decommissioning practices. To meet this requirement, the license holder shall ensure:
  - a. selection and control of materials;

- b. recycling and reuse of materials, including clearance of materials;
- c. implementing adequate operating procedures, including those referring to the physical, chemical and radiological characterization of the waste, and sorting of different type of materials.
- All spent fuel and radioactive waste are to be safely managed using a graded approach, applying an appropriate combination of engineered systems and management controls.
- The financial costs for waste management and disposal operations should be borne by the waste producers in accordance with the 'polluter pays' principle, and a statutory funding scheme is in place.

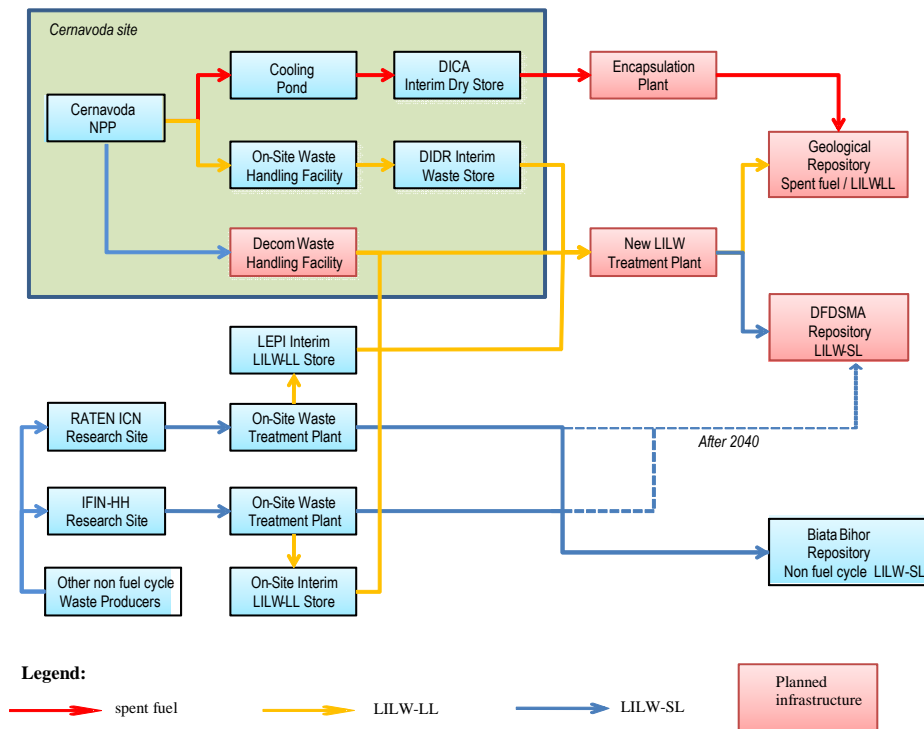

**Figure B1: The National Strategy on Medium and Long Term Management of Spent Nuclear Fuel and Radioactive Waste**

- All spent fuel and radioactive waste are to be managed according to an integrated strategy that addresses interdependencies between all waste management steps which includes pre-treatment, treatment, conditioning, storage, transport and disposal.
- Disposal is the last stage of the radioactive waste management system. Wastes are to be disposed with no intention to be retrieved. A graded approach is adopted, with the disposal concept commensurate with the level of hazard posed by the waste:
  - a. spent fuel from power reactors will be directly disposed to a geological repository after an appropriate period of interim storage, together with other long-lived radioactive wastes;
  - b. short-lived operational and decommissioning waste will be disposed to surface or near-surface repositories.
- Facility decommissioning, waste management and disposal operations will be undertaken as soon as reasonably practicable to avoid placing an undue burden on future generations, and implementation programmes have been prepared with key milestone dates.

- Non nuclear fuel cycle radioactive waste LILW-SL are disposed in Baita-Bihor repository (DNDR), which is in operation since 1985;
- According to international agreements signed with neighbor countries, the protection of human health and environment beyond national borders shall be assured in such a way that the actual and potential health effects will be not more detrimental than those accepted for Romania.
- The discharges of gaseous and liquid radioactive effluents from any nuclear facility shall be limited, according to the derived emission limits approved by CNCAN, and further reduced, according to the optimization principle.
- The strategies for the management of spent nuclear fuel as well as for the management of radioactive waste are presented in the Figure B1.

## B2. Spent fuel and radioactive waste management practices

Location on the map of the main organizations involved in radioactive waste/spent fuel management is shown in Figure B2.

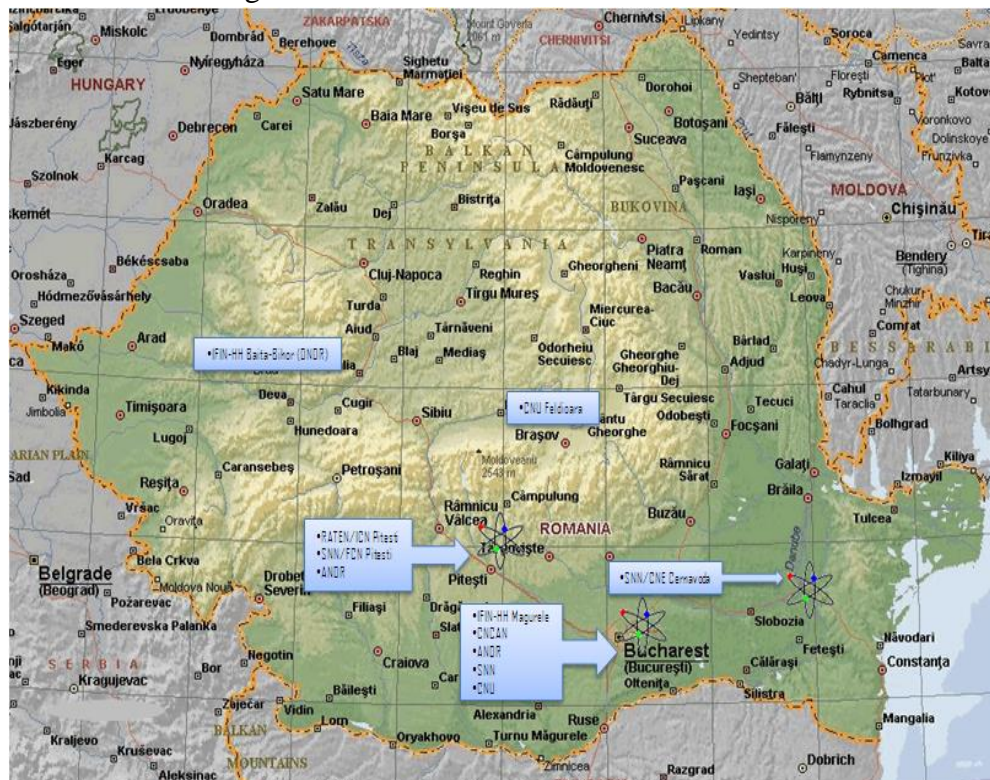

Figure B2: Romanian map – Location of the main organizations involved in radioactive waste/spent fuel management

### B2.1 Spent fuel practices

#### B2.1.1. Spent fuel from NPP

CNE Cernavoda is located at 1 km distance from the Cernavoda town, close to Danube River. CNE Cernavoda, the operator of the Cernavoda NPP-Units 1 and 2, has the following spent fuel management facilities:

- The Spent Fuel Handling System (for each unit);
- The Interim Spent Fuel Dry Storage Facility - DICA.

The facilities are located on the NPP site.

*a) The Spent Fuel Handling System*

A wet spent fuel management facility, specifically named Spent Fuel Handling System, was provided for each reactor, as part of the NPP project. This system includes the following:

- Discharge and Transfer Equipment located in the Reactor Building;
- Spent Fuel Reception and Storage Equipment located in the Service Building;
- Spent Fuel Reception Bay located in the Service Building;
- Spent Fuel Bay (main storage bay) and Defective Fuel Bay, located in the Service Building.

The transfer of spent fuel between Reactor Building and Service Building is underwater through a Transfer Channel.

According to design data, the Spent Fuel Bay has a capacity of 50,000 CANDU fuel bundles and the Defective Fuel Bay has a capacity to store for thirty years of plant operation the cans with defected fuel. Sixteen cans are initially provided, each with capacity of one bundle.

*b) The Interim Spent Fuel Dry Storage Facility (DICA)*

After at least six years in the wet storage facility, the spent fuel is transferred to the dry storage facility, DICA (*Figure B3*).



**Figure B3: DICA**

The dry storage technology is based on the MACSTOR System. The basic principle of dry storage systems could be summarized as: "The storage of spent fuel for a minimum of 50 years under nuclear safety conditions both for operator and population and for the environment" by:

- providing the confinement of the fuel (exclusive the fuel cladding);
- removal of residual heat of stored fuel by natural convection of air;
- securing the storage area against external phenomena (natural and human-induced);
- Ensuring adequate shielding.

The DICA objective involves three main activities, which take place in three different locations on the CNE Cernavoda site, as follows:

- a) preparation of spent fuel for dry storage at DICA;
- b) transfer of spent fuel from U1 and U2 to DICA;
- c) proper storage at DICA.

The spent fuel is transferred from the wet storage facility to the storage basket. The storage basket is made of 304L stainless steel. The 60 spent fuel bundles are transferred one by one from the existing storage blades (horizontal position) and placed in a vertical position in the storage basket. Loading is done under water on a support table, and the basket is placed on an underwater stroller placed on another support table for transfer to the spent fuel load station.

The spent fuel load station consists of an enclosure with gamma and neutron shielding where the full storage basket is received, decontaminated under pressure with demineralised water, dried, sealed by two welds and visually inspected. The sealed storage basket provides the first barrier to confinement to the environment, without considering the fuel cladding.

Transfer of the spent fuel from CNE to DICA is done using a trailer that takes the transfer container containing a storage basket with 60 fuel bundles and transports it to DICA on a specific route that is not connected to the public road.

DICA is a modular type construction, allowing for staged construction, as the spent fuel is transferred from the wet storage facility. DICA is designed to store the spent fuel from CNE Cernavoda Units 1 and 2, for 27 modules type MACSTOR 200. Up to now, 8 modules are in operation.

Each module consists of a reinforced concrete parallelepiped construction of approximately 21.6 m x 8.1 m x 7.5 m, which embeds 20 metallic storage cylinders vertically positioned, each cylinder ensuring the storage of 10 spent fuel baskets. Once filled, the cylinder is sealed according to the requirements of EURATOM and the IAEA. Each module has the capacity of storing  $10 \times 20 \times 60 = 12,000$  spent fuel bundles.

The welded cylinder of the cover plate is the second barrier to confine the fuel to the environment.

Characteristic of this project is that it provides two barriers to confine the spent fuel (basket and cylinder), without considering the fuel cladding.

The condition of fuel stored inside the modules is periodically assessed by taking samples from the air inside the storage cylinders to check the integrity of the two containment barriers. The level of radiation in the vicinity of the module walls is also periodically monitored.



The dry storage facility for spent fuel located in Cernavoda has been subject to a systematic safety review in accordance with the technical specification defined by ENSREG as part of the EU NPPs Stress test.

The results of the evaluation show the dry storage facility as being robust, with a significant safety margin for all the initiating events considered as part of the evaluation (earthquakes, external flooding and severe weather events). Consequently no changes on the design basis have been identified as being required.

There are no specific ageing management programs for DICA facility.

### ***B2.1.2. Spent fuel from the research reactors***

#### ***B2.1.2.1 ICN Pitesti***

ICN Pitesti, the operator of TRIGA reactor, has the following spent fuel management facilities:

- The Spent Fuel Pool;
- The Dry Storage Pits.

##### **a) The Spent Fuel Storage Pool**

The TRIGA reactor is a pool type reactor with 2 cores: Steady State Reactor operated at maximum 14 MW and Annulus Core Pulse Reactor that can be operated for a maximum pulse of 20,000 MW or can be operated in steady state mod for a maximum 500 KW.

The fuel originally used for Steady State Reactor was HEU type, 93% enrichment.

In present the full conversion of the core to use LEU type 20% enrichment is accomplished. The Annulus Core Pulse Reactor fuel is LEU type 20% enrichment.

The spent fuel removed from the TRIGA reactor can be stored for one year in the reactor pool, in 6-bundle racks. After this delay time the spent fuel bundles are transferred in the spent fuel storage pool. Storage conditions are similar to those in the TRIGA pool. The storage time could be 20 to 30 years. Romania has adhered to the US Government policy with respect to return to the country of origin the HEU type spent fuel in American research reactors abroad. According to the agreement signed by Romania, in 2006, all the HEU type fuel has been removed from reactor and returned to USA.

##### **b) The Dry Storage Pits of LEPI**

Solid radioactive waste generated in the hot cells, during the fuel post irradiation examination, can be stored in 13 dry storage pits (*Figure B4*). These pits are stainless steel tubes, located in the experimental cell basement, closed with superior end plugs. Storage racks inside pits can accommodate spent fuel rods or fragments stored in stainless steel cans.



**Figure B4: The Storage Pits at LEPI for Irradiated Experimental Fuel Rods and Fragments**

#### ***B2.1.2.2 IFIN-HH***

IFIN-HH is the owner of VVR-S Research Reactor which is now under decommissioning. There is no nuclear fuel on site.

#### ***B2.2. Radioactive waste management practices***

##### ***B2.2.1. Management of radioactive waste from NPP***

CNE Cernavoda has the designated facilities for proper current management of its gaseous, liquid (aqueous and organic), spent resins and solid operational radioactive wastes, in order to ensure the protection of the workers, public and environment.

##### ***a) The Gaseous Radioactive Waste System***

Potentially contaminated air is circulated through four ventilation systems:

- *Central Contaminated Exhaust System*: the air from this system is filtered through a High Efficiency Particulate Air (HEPA) filter.
- *Reactor Building Exhaust System*: the air from the Reactor Building is passed through a pre-filter, a HEPA filter, an activated charcoal filter (to retain radioiodine) and a final HEPA filter.

- *Spent Fuel Bay Exhaust System*: filtration of this air is similar to that of the Reactor Building.
- *Upgraded Tower Exhaust System*: the air from this system is unfiltered since it contains small tritium quantities, only.

In areas of the reactor building where heavy water systems are located, a Closed Cycle Vapors Recovery System recovers the majority of released tritium vapors.

All potentially contaminated air is routed to the exhaust stack, for discharge.

#### *b) The Aqueous Liquid Radioactive Waste System*

The radioactive aqueous liquid wastes are collected in five liquid effluent hold-up tanks. They are located in the basement of Service Building. Each tank has a capacity of 50 m<sup>3</sup>.

A decontamination unit is provided to minimize the radioactive particles in any effluents if necessary. It includes filtering and ionic exchange by means of a pre-coat type filter using as filtering material ionic micro-resins and a special fiber material adequate for the colloidal filtration since the main contaminants consists of a combination of colloidal particles and ionic materials within deionization water medium.

#### *c) The Spent Resins Handling System*

The Spent Resins Handling System includes storage tanks for spent resins from the plant's purification circuits.

The spent resins are stored in three vaults made of reinforced concrete lined with epoxy, located in the basement of the Service Building, in the proximity of the Reactor Building. The capacity of each vault is of 200 m<sup>3</sup>.

#### *d) The Solid Radioactive Waste System*

After pretreatment and treatment the solid wastes are confined in 220L stainless steel drums (type A container) and transported to the Solid Radioactive Waste Interim Storage Facility - DIDR (*Figure B5*).

DIDR is located within the inner security fence of the plant site and is designed for storage of low and intermediate wastes. It has a storage capacity of 1,506.77 m<sup>3</sup>, covering the radioactive waste produced by operation of CNE Cernavoda Unit1 and Unit 2, except spent resins, reactivity control rods and spent fuel.

It consists of three above ground structures with a designed life of 50 years, as follows:

- The Structure no. 1 (concrete warehouse)
- The Structure no. 2 (concrete cylindrical cells)
- The Structure no. 3 (concrete cubes).

*The Structure no. 1 – a warehouse (Figure B6)* is a concrete building with a net storage capacity of 1,408 m<sup>3</sup>. Inside this structure 220L stainless steel drums containing compactable and non-compactable solid radioactive waste (Type 1 and Type 2) can be stacked on four levels.

*The Structure no. 2* – is a concrete structure which consists of cylindrical concrete cells dimensioned to accommodate spent filter cartridges resulted from plant operation. Its designed storage capacity is of 57.77 m<sup>3</sup>. Inside the concrete cells there are metallic cells with bottom and cover designed to avoid spreading of contamination.



**Figure B5: DIDR – outside**



**Figure B6: DIDR - The structure no. 1 – warehouse inside**

*The Structure no. 3* – is a concrete structure for large and highly contaminated pieces with a total storage capacity of 41 m<sup>3</sup>. It consists of eight concrete cubes which can be removed together with the waste content. Currently, the structure does not contain any waste.

### ***B2.2.2. Radioactive waste from nuclear fuel fabrication***

The Nuclear Fuel Plant (FCN) in Pitesti has the designated facilities for proper current management of its gaseous, liquid and solid wastes, in order to ensure protection to the workers, public and environment.

#### *a) The Gaseous Radioactive Waste System*

Air from potential contaminated indoors (areas dedicated to the fuel manufacturing and laboratories' rooms) is collected, filtered with high efficiency pre-filters and discharged through the plant's stacks.

#### *b) The Liquid Radioactive Waste and Radioactive Effluents*

The storage of the radioactive liquid wastes is made inside the basement of the Plant Building. Facilities for storage for a short period of time are: 6 stainless steel tanks of 10 m<sup>3</sup> for radioactive liquid wastes (LILW-LL) and 3 tanks of 60 m<sup>3</sup> each (50 m<sup>3</sup> useful capacity) for radioactive liquid effluents.

They collect and store the different categories of liquid wastes.

The liquid radioactive waste, are sent to a licensed radioactive waste operator, Radioactive Waste Treatment Station (STDR) that belong RATEN ICN Pitesti on the same platform, based on administrative arrangements for appropriate treatment and uranium recovery in solid uranyl phosphate form. The uranyl phosphate is returned to FCN.

The liquid radioactive effluents are sent to Purification Station that belong RATEN ICN Pitesti for treatment and discharge in the river.

#### *c) The Solid Radioactive Waste*

The solid radioactive waste are low contaminated only with natural uranium. Storage of low contaminated solid radioactive waste is performed on Platform for Temporary Storage of Solid Radioactive Waste (PDT). This is a platform on the ground located in the vicinity of the building of fuel manufacturing in FCN perimeter. It is covered and enclosed with controlled access. In the neighborhood of PDT there is a security fence with a physical protection system.

The PDT is dedicated to temporary storage of different categories of solid waste collected in the plant and further, in short term, transferred to different waste operators.

The combustible radioactive solid waste, containing natural uranium for a recovery are collected, packaged and sent to STDR that belong to RATEN ICN Pitesti for further treatment by incineration. The uranium ashes obtained after incineration of the combustible radioactive solid waste are returned to FCN Pitesti.

The non-combustible radioactive solid waste, containing waste for which no any recovery is intended, are sent to the Feldioara repository for disposal based on transfer authorization issued by CNCAN.

The policy at the plant is to transfer the waste, as soon as possible, since its generation, to the waste operators.

The platform can store about 50 m<sup>3</sup> (40 tons) radioactive solid wastes.

### ***B2.2.3 Management of non-fuel cycle radioactive waste***

The management of non-fuel cycle radioactive waste is done by IFIN-HH and ICN on the sites of the research reactors at Bucharest and Pitesti, in their treatment and conditioning facilities.

The conditioned non fuel cycle radioactive waste is disposed of the National Repository for Radioactive Waste (DNDR) located in Baita Bihor and operated by IFIN-HH.

The non-fuel cycle radioactive waste which do not meet WAC for disposal at DNDR are stored in surface storage buildings at the IFIN-HH site.

Spent sealed radioactive sources with high activity and long lived radioactive waste resulted from the TRIGA reactor are stored in Post Irradiation Examination Facility (LEPI) at the ICN Pitesti site.

#### ***B2.2.3.1. Management of non-fuel cycle radioactive waste at IFIN-HH***

The management of the non-fuel cycle radioactive waste is performed at IFIN–HH through a specialized department. The Radioactive Waste Management Department (DMDR) is the operator of two important facilities at the national scale:

- Radioactive Waste Treatment Plant (STDR);
- National Repository for Low and Intermediate Level Waste, Baita – Bihor (DNDR).

The aim of DMDR is the management at the national level of all non-fuel cycle radioactive waste generated from nuclear techniques and technologies applications in areas as industry, agriculture, research, education, medicine assuring the radiological safety of operators, population and environment.

Radioactive wastes including spent sealed radioactive sources are collected and radiological characterized. The radioactive waste which meets the waste acceptance criteria of DNDR Baita Bihor is treated and conditioned. The radioactive wastes which do not meet waste acceptance criteria of DNDR are stored on site.

The main activities of the radioactive waste management process are the following:

- Collection of radioactive waste with licensed car and specialized personnel;
- Transport of radioactive materials (Class 7) weighting up to 40 t, equipped with crane for loading / unloading of large sized items ;
- Segregation and handling of radioactive waste and of clearable material;
- Radioactive, chemical, structural and mechanical characterization for all steps of processing flow-sheet;

- Treatment/confinement/conditioning of liquid and solid radioactive waste for storage and / or disposal;
- Radioactive sealed sources transfer for conditioning/storing/reusing;
- Management of radioactive materials under the safeguards regime;
- Expertise in the management of historical radioactive waste, and technical assistance for measurements and preparation of documents for disposal/ free release;
- Storage of radioactive waste including spent sealed radioactive sources;
- Disposal of conditioned radioactive waste packages;

The storage facility is a ground floor building, divided into 5 rooms. The total storage capacity is about 2,160 m<sup>3</sup>. The storage building has been modernized in 2012. One of the five rooms is designated as storage area for depleted uranium, having a total storage capacity of 432 m<sup>3</sup>.

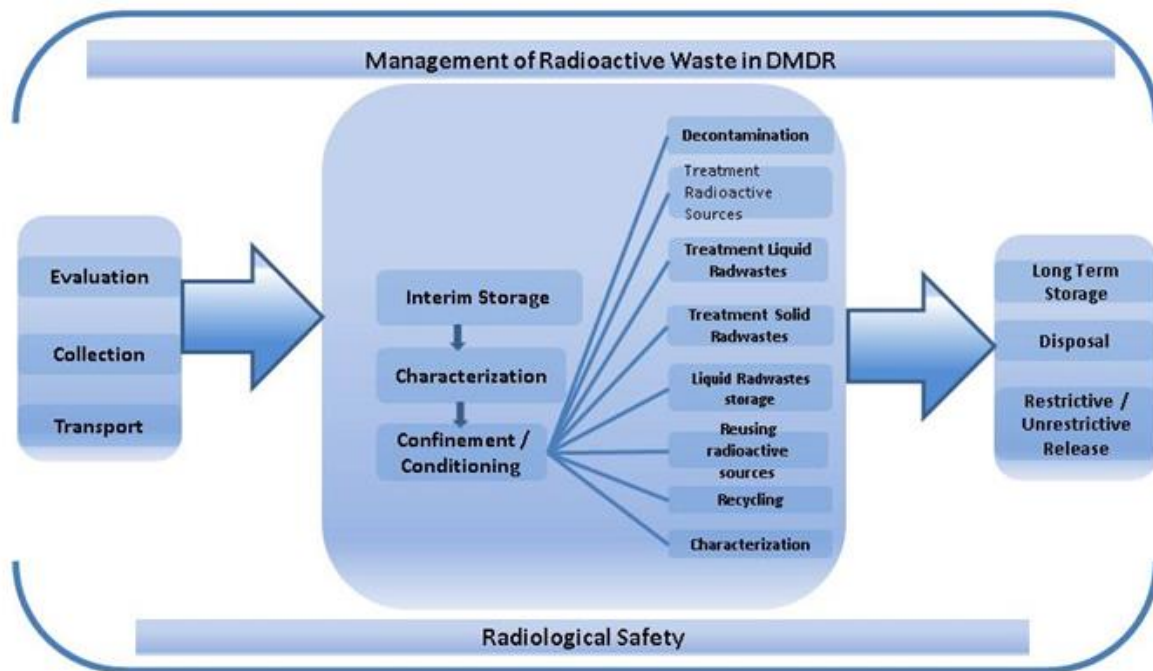

**Figure B7: IFIN-HH Radioactive waste management scheme**

#### ***B.2.2.3.2. Disposal of radioactive waste***

The disposal of non-fuel cycle radioactive waste is performed in the National Repository for Low and Intermediate Level Wastes Baita – Bihor. The repository is located at an elevation of 840 m in two disused exploration galleries of the Baita uranium mine (Gallery 50 and Gallery 53 – the latter is currently being used for ventilation purposes). Galleries 50 and 53 are part of an extensive network of interconnected uranium exploration and exploitation galleries associated with the mining operations. Gallery 50, and certain transverse galleries leading from it, were enlarged and modified to make them suitable for waste disposal prior to the commencement of repository operations in 1985.

The Baita Bihor repository was designed to accommodate around 5,000 m<sup>3</sup> of conditioned wastes disposed in about 21,000 standard containers. The first waste disposals were made in

1985 and it is assumed that disposals will continue until 2040. The repository layout is presented in Figure B8.

The disposal galleries are former exploration galleries that have been enlarged and provided with a drainage system and appropriate infrastructure installed to make them suitable for waste disposal. Since 1985, waste has been disposed in a series of transverse galleries that are perpendicular to the main access gallery (Gallery 50). Once all the 11 transverse galleries will be filled, the part of the Gallery 50 between Galleries 31/1 and 13/1 will be filled with waste.

The disposal galleries consist of the following components:

*1. Gallery Ceilings, Walls and Floors*

There is no general reinforcement or waterproofing of the walls or ceilings in the disposal galleries. However, any local areas of infiltration were grouted during construction, rock bolts and other reinforcement were installed as required and most of the interior surfaces of the repository are covered by gunite (sprayed concrete). The base of all galleries is lined with a 50 mm thick concrete floor that slopes at 0.5% towards a central drain.

*2. Disposal Containers*

A range of sizes of authorized disposal packages is used for the disposal of the radioactive waste. The disposal packages consist of cementitious waste form within 220 L or 420 L painted mild steel drums.

*3. Waste Form*

In all cases, the waste form comprises a monolith of a cementitious material. The cementitious material used is generally Ordinary Portland Cement (OPC) incorporating sand and/or gravel.

*4. Bentonite backfill*

Prior to 1996, the waste drums were simply stacked in the galleries. It was so until 1996 when backfill between the disposal packages was introduced. Powdered bentonite was selected as the backfilling material following evaluation of sand, bentonite, clay and concrete/bentonite mix as potential backfilling materials.

*5. Wooden Shuttering*

Wooden shuttering is used in the bentonite backfilled galleries to form and contain the bentonite. The shuttering is not recovered following disposal of the drums.

*6. Closure Walls*

Once full, the disposal galleries are closed with a simple block wall. The blocks are cemented in place but there is no additional engineering, such as buttressing to resist lateral forces. However, in the backfilled galleries, the void space behind the wall is backfilled with bentonite.



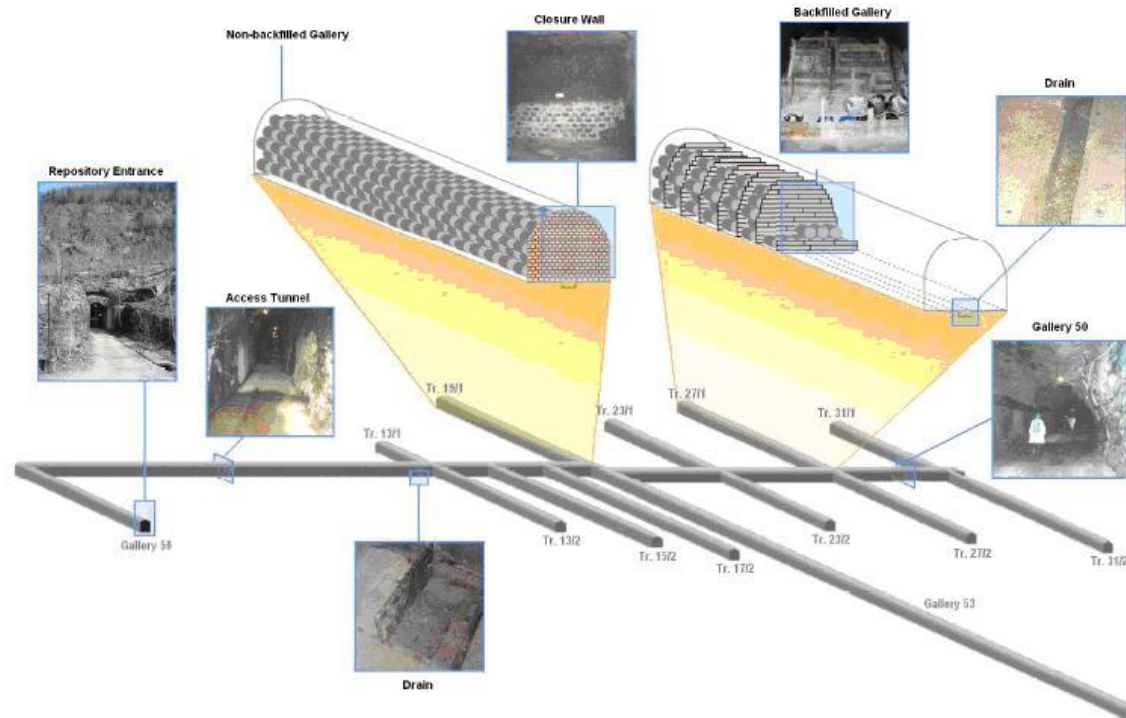

**Figure B8: Disposal Galleries at DNDR Baita - Bihor**

In the period 2008 - 2010 a Phare project “Upgrading of Baita Bihor repository” was implemented. The objective of this project was the improvement of the operation of the Baita-Bihor repository for low and intermediate level radioactive waste, addressing both the safety of disposal operations at the repository and also improving the long-term, post-closure, performance of the repository.

The main refurbishment activities recommended by the above mentioned project implemented to Baita Bihor repository refers to the reconditioning of the access and disposal galleries, as well as the upgrading of the repository support systems, namely: ventilation system, drainage system, fire detection system, physical protection of the repository, instrumentation and control systems associated with the repository operation. Also, an administrative building and total refurbishment of the unloading platform are part of the refurbishment recommendations.

As a general conclusion of the safety assessment (and its supporting HAZOP study) is that the refurbishment/replacement activities associated to the repository upgrade do not represent a challenge to safety, in terms of radiological impact and also for the industrial or health concerns, but an essential improvement assuring not only the short term operational period, but also for long term period (post-closure). There were also some new abnormal (incident) scenarios revealed, that were evaluated in the revised operational safety assessment of repository.

The individual annual effective doses from normal operations, considering that a worker is involved in all operations, over the period 2005 to 2025, are around 6 mSv, i.e. more than a factor of three below the regulatory limit of 20 mSv.

The implementation of the upgrading works was finalized accordingly and they have a major impact on the radiological risk assessments as relevant as the impact of the operating conditions of the facility.

### ***B2.2.3.3 Management of own radioactive waste at ICN Pitesti***

The management of the own radioactive wastes is performed at ICN Pitesti. In the scope of management of radioactive waste ICN Pitesti has in operation two facilities: Radioactive Waste Treatment Facility and Post Irradiation Examination Laboratory.

The management of the own radioactive waste at ICN Pitesti is performed in Radioactive Waste Treatment Facility.

Waste treatment and conditioning technologies used at ICN Pitesti are the following:

- Solid waste – embedding into concrete (220 L drum with basket or well);
- Spent ion exchangers – bituminization (80 L can) followed by embedding into concrete (220 L drum);
- Solid waste contaminated with natural uranium – incineration with uranium recovery;
- Aqueous liquid waste – evaporation and embedding of the concentrate into concrete (218 L drum);
- Organic liquid waste – embedding into concrete with additives (218 L drum);
- Aqueous liquid waste contaminated with natural uranium – chemical treatment with uranium recovery;
- Aqueous liquid waste from CNE Cernavoda – ion exchange.

The main activities of the radioactive waste management process are the following:

- Waste collection, segregation, packing, labeling;
- Characterization by sampling and in situ/ex situ;
- Package dosimetric/contamination measurements;
- Radioactive waste transfer to waste treatment plant;
- Treatment according with technology;
- Characterization of treated waste before conditioning, where is applicable;
- Conditioning according with technology;
- Confirmatory measurements and release of waste package certification report.

Radioactive waste management scheme applicable at ICN Pitesti is presented in figure B9.

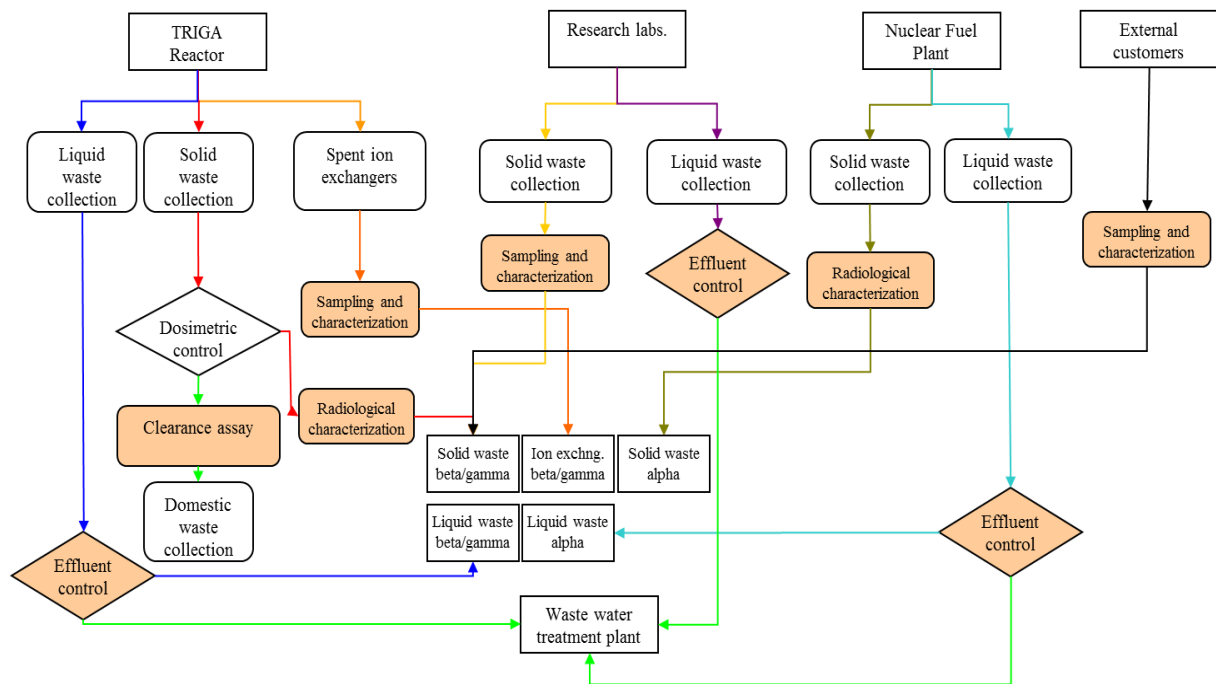

**Figure B9: ICN Pitesti Radioactive Waste Management Scheme**

The radioactive waste which meet the waste acceptance criteria of DNDR Baita are treated and conditioned using the existing installations from STDR. The conditioned radioactive waste are transferred, transported and disposed of at DNDR Baita. The radioactive waste which does not meet the waste acceptance criteria for disposal at DNDR Baita are stored in dry storage pits at LEPI.

Optimisation of the existing technologies, developing new technologies for radioactive waste treatment and conditioning as well as implementing of methods for measurement of difficult to measure radionuclides are performed under R&D program having the following main research directions:

- Radioactive waste characterization: methods development and implementation for difficult to measure radionuclides;
- Development of new technologies for treatment and conditioning of various types of radioactive waste (molecular sieve, sludge) generated from CNE Cernavoda operation, maintenance and decommissioning, from ICN nuclear installations and from other applications of nuclear techniques;
- Design, development and testing of the spent fuel storage and transfer cask;
- Development of experimental and modelling methodologies to support the safe storage and disposal of low and intermediate level radioactive waste;
- Long term behavior of spent nuclear fuel under storage and disposal conditions
- Developing of the geological disposal concept for long-lived radioactive waste and CANDU spent fuel disposal;
- Nuclear facilities decommissioning.

Post Irradiation Examination Laboratory (LEPI) is designated mainly for research activities and for storage of LILW-SL and LILW-LL produced at ICN site, that do not meet the

WAC of Baita Bihor repository, including high activity spent sources collected from all over the country.

#### ***B2.2.4. Radioactive waste from uranium mining and milling***

The Uranium National Company (CNU) is responsible for uranium mining and milling activities as following:

- Feldioara Subsidiary:
  - o Settling and storage the radioactive tailings resulted from milling process
  - o Storage the solid radioactive materials
- Ștei (Bihor) Working point:
  - o Environmental restoration/ remediation of sterile and radioactive rocks dumps resulted from research and uranium mining activities at Avram Iancu mine
- Suceava Subsidiary:
  - o Storage and environmental restoration/ remediation of sterile and radioactive rocks dumps resulted from research and uranium mining activities
- Oravița (Banat) Working point:
  - o Management of Lisava and Ciudanovita mine water treatment stations

S.C. Conversmin S.A. is a company subordinated to the Ministry of Economy, responsible for the management of the budget funds allocated to mines closure and environmental restoration, including uranium mines. The decommissioning and restoration works managed by S.C. Conversmin S.A. are in progress at Avram Iancu, Ciudanovita and Dealu Morii. The environmental restoration is made by subcontractors of S.C. Conversmin S.A.

The Radioactive Mineral Magurele Company is responsible for the restoration of environment from the old uranium mining practices that are not under the responsibility of Uranium National Company (see above).

Geolex S.A. is a small company, dedicated for geological works and exploration. The activities related to uranium and thorium are now closed, Jolotca mining sector, for which this company was responsible, is now totally restored.

#### ***CNU - Feldioara Subsidiary***

CNU Feldioara Subsidiary is located at about 30 km from the Brasov town (250,000 inhabitants). Since the commissioning of the plant, the tailings resulted from the milling process were discharged in 2 special insulated tailings ponds, under a variable water strata, located at 600 m from the plant area.

The location and insulation system were realized taking into account the “National safety standards for geological research, radioactive raw materials mining and milling“, issued in 1975. The geographic criteria were the presence of a clay deposit within the area, enhancing the possibilities for a good insulation, and also the presence of the Cetatua natural valley, suitable for building a long and stable pond. The 2 tailings ponds are named Cetatua II and Mittelzop.

The Cetatua II have as aim the settling and storage of radioactive tailings, and was built in 3 parts, due to high investment costs for insulation of the concerned surfaces. The present state of this pond is the following:

- the first part, is now in a closing out process, being used for tailings discharging in the 1978 - 2001 period. The total estimated tailings discharged were about 2,120,000 m<sup>3</sup> and the total surface of this first part is 368,000 m<sup>2</sup>. The closure of the pond will transform it in a repository;
- the second part of the Cetatua II pond was commissioned in October 2001, after completion of complex insulation work. The discharging capacity is estimated at 414,500 m<sup>3</sup> of tailings, on a 133,000 m<sup>2</sup>.

The Mittelzop pond has as aim the final tailings settling of fines, receiving the inflow from the Cetatua pond waters. This pond was commissioned in 1978, at the same date with Cetatua pond and the milling plant. The volume is about 300,000 m<sup>3</sup>, on an 87,000 m<sup>2</sup> surface. The dam of this pond has 5 m height. From the pond the clear waters are pumped to the decontamination plant (where the remaining traces of uranium are removed) and then to the Olt river.

In order to adjust other parameters, as pH, content of salts, content of heavy metals, of industrial water before the release into environment, it was built a new treatment water facility. This is located near old radioactive decontamination plant and it will treat industrial water after decontamination, using reverse osmosis technology. For temporary storage of salts resulting from the treatment facility were built two new warehouses located not far from the landfill for solid contaminants.

After closure, all the tailing ponds will be transformed in repositories.

For the ponds the main insulation works were as follows:

- the bottom of ponds was insulated with two layers, 30 cm thick, of clay.
- the right slope of the ponds was protected by two layers of polyethylene (plastic) foil, and a sandwich of special bitumen - rubber materials;
- the left slope, being located on a clay deposit;
- it was built a rain water drainage system used also for draining the surroundings of the ponds.

In 1996, a channel was built between the Cetatua and Mittelzop ponds, enabling the natural flowing of pond water, without using pumps.

Between the two mentioned ponds there is a solid radioactive material discharge area, composed by two old trench type storage facilities and a new storage facility.

The new storage area for radioactive solid waste is protected by concrete walls, 5 m high. The maximum storage volume was increased to 15,083 m<sup>3</sup>. The foundation consists of compacted clay.

On an area of 3 km around the plant and tailing ponds there are no inhabitants to be exposed to radiological hazard due to radioactive materials discharge.

### **B2.2.5. Decommissioning**

In Romania there is only one nuclear facility under decommissioning, namely the VVR-S research reactor from IFIN-HH Magurele. The reactor was shut down in 1997, being till 2010 under a conservation licence, and since December 2010 is under decommissioning license. The decommissioning licence has been issued by CNCAN for the first phase (2010-2013) and for second phase (2013-2014); the third phase is foreseen for (2015-2020). More details are presented into Section F6.5.

### ***B3. Criteria to define and categorize radioactive waste***

According to the definition presented in the Law no. 111/1996 on the safe deployment, regulation, licensing and control of nuclear activities, republished, the radioactive wastes are those materials resulted from nuclear activities for which no use was foreseen, and which contain or are contaminated with radionuclides in concentration above the exemption limits.

According to the provisions of the CNCAN Order No. 156/2005 for approval the Regulation on the classification of radioactive waste, the general classification of radioactive waste is the following:

- excluded radioactive waste (EW)
- transitional radioactive waste (TW)
- very low level radioactive waste (VLLW)
- low and interim level short lived radioactive waste (LILW-SL)
- low and interim level long lived radioactive waste (LILW-LL)
- high level radioactive waste (HLW).

The general classification refers to the requirements for assuring the isolation from biosphere of the radioactive waste during its disposal.

The excluded radioactive waste is waste containing radionuclides with an activity concentration so small that the waste can be released from regulatory control.

The transitional radioactive waste is waste having activity concentration above clearance levels, but which decays below clearance levels within a reasonable storage period (not more than 5 years).

The very low level radioactive waste is short lived waste in which the activity concentration is above the clearance levels, but with a radioactive content below levels established by CNCAN for defining the low level waste. The disposal of very low level waste requires less complex arrangements than the disposal of short lived low level waste.

The low and intermediate level radioactive waste is radioactive waste in which the activity concentration is above the levels established by CNCAN for the definition of very low level waste, but with a radioactive content and thermal power below those of high level waste. Low level waste does not require shielding during handling or transportation. Intermediate level waste generally requires shielding during handling, but needs little or no provision for heat dissipation during handling or transportation.

The long lived radioactive waste is a waste containing radionuclides with half-life above 30 years in quantities and/or concentrations of activity above the values established by CNCAN, for which isolation from biosphere is necessary for more time than the institutional control duration. The short lived radioactive waste is a radioactive waste that is not long lived.

The high level radioactive waste is:

- a) liquid radioactive waste containing the most part of fission products and actinides existing initially in the spent fuel and forming the residues of the first extraction cycle of reprocessing;
- b) the solidified radioactive waste of letter a) and the spent fuel;
- c) any other radioactive waste with activity concentration range similar to the waste mentioned at letter a) and b).

According to the above mentioned regulation, each waste producer shall establish an operational classification of the waste that it manages.

The operational classification of radioactive waste is performed taking into account: origin and types of the waste, nuclear and radiological properties, management options, other properties such as: physico-chemical and biological properties/hazards corrosivity, content of free liquids, flammability, volatility, solubility, miscibility, dispersibility, organic content, complexing/chelating agents, reactivity, sorption of radionuclides, swelling potential, chemically or biologically hazardous substances, etc.

Based on the generation route the radioactive waste are classified on non-fuel cycle waste and fuel cycle waste.

## **SECTION C. SCOPE OF APPLICATION (*Article 3*)**

***Article 3.1:*** Romania does not reprocess spent fuel, as it was decided to use open fuel cycle. By consequence Romania does not declare reprocessing to be part of spent fuel management.

***Article 3.2:*** Romania does not declare as radioactive waste for the purposes of the Convention any waste that contains only naturally occurring radioactive material and does not originate from the nuclear fuel cycle.

***Article 3.3:*** Romania does not have military or defense programs that produce spent fuel. The very low amounts of radioactive waste that result from radiological practices in military area, are transferred permanently to and managed within exclusively civilian programs. By consequence Romania does not declare spent fuel or radioactive waste within military or defense programs as spent fuel or radioactive waste for the purposes of the Convention.



## **SECTION D. INVENTORIES AND LISTS (*Article 32*)**

### ***D1. List of Spent Fuel Management Facilities***

[Annex L-1](#) (Section L) lists the Romanian Spent Fuel Management Facilities.

### ***D2. Spent Fuel Inventory***

[Annex L-2](#) (Section L) lists the inventory of spent nuclear fuel in *storage* at the end of 2016.

### ***D3. List of Radioactive Waste Management Facilities***

[Annex L-3](#) (Section L) lists the Romanian Radioactive Waste Management Facilities.

### ***D4. Radioactive Waste Inventory***

[Annex L-4](#) (Section L) lists the inventory of RW in storage at the end of 2016.

[Annex L-5](#) (Section L) lists the inventory of RW disposed of at DNDR – Baita Bihor at the end of 2016.

## **SECTION E. LEGISLATIVE AND REGULATORY SYSTEM**

### ***E1. Implementing measures (Article 18)***

Romania has ratified by the Law no. 105 / 1999 the Joint Convention on the safe management of spent fuel and on the safe management of radioactive waste.

The Law no. 111/1996 on the safe deployment, regulation, licensing and control of nuclear activities, hereinafter called the Law no. 111/1996, provides the legislative framework governing the safety of nuclear and radiological facilities. The purpose of the Law is to provide for a comprehensive legal framework for the regulation, licensing and control of all activities related to the peaceful use of nuclear energy.

The Law no. 111/1996 empowers the National Commission for Nuclear Activities Control (CNCAN), which is the national nuclear regulatory authority, to issue mandatory regulations, to grant licences for nuclear facilities and activities, to perform assessments and inspections in order to verify the compliance with the nuclear safety requirements and to take any necessary enforcement actions. CNCAN is the only nuclear regulatory authority in Romania. The list of the regulations issued by CNCAN is presented in the Annex L-6.

The Law establishes the obligations of the licensees and defines the responsibilities of other Governmental authorities in implementation of the provisions of the Law (more information in Section E4).

Licensing regime as well as control regime is established in the framework of the Law 111/1996.

The provisions of the Law no. 111/1996 and regulations issued by CNCAN take due account of the objectives of the Joint Convention.

Thus it can be concluded that the obligations under article 18 of the Joint Convention are met by Romania.

### ***E2. Legislative and regulatory framework (Article 19)***

#### ***E2.1. Establishing and maintaining of legislative and regulatory framework***

In Romania the regulatory framework is a pyramidal one and consists of three levels. In the top of pyramid there are laws, on the second level there are fundamental regulations on radiological safety and on the third level there are specific regulations, regulatory letters and CNCAN dispositions (see Figure E1).

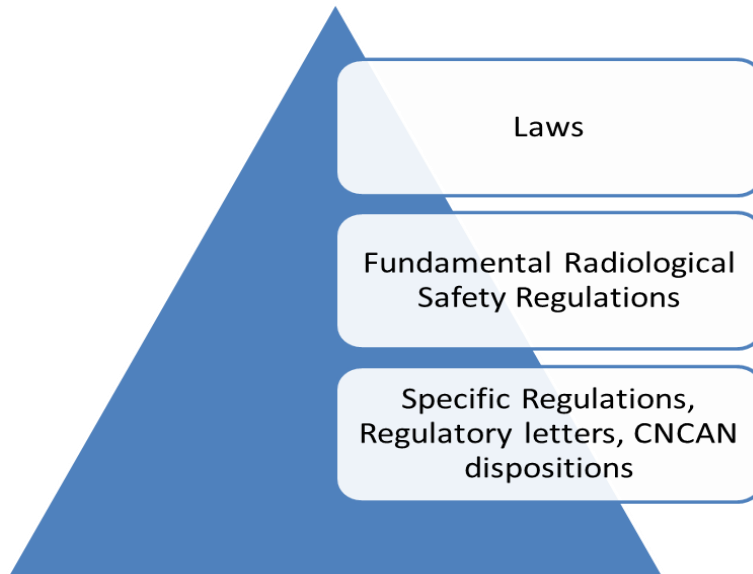

**Figure E1 – Regulatory system pyramid**

### ***E2.2. Provisions of legislative and regulatory framework***

In the [Annex L-6](#) of this report there is the list of the applicable regulations in force in the field of spent nuclear fuel and radioactive waste.

#### ***Development of regulations***

CNCAN develops regulations in accordance with the Law 24/2000, on “Legislative technique for elaboration of the normative acts” and the Governmental Decision HG 561/2009 on the approval of the Regulation regarding the procedures for elaboration of public policy documents, which establish the general provisions, technical rules and administrative procedures for the development of all Romanian regulations (normative acts).

All the regulations issued by CNCAN are mandatory and enforceable. The regulations are developed in observance of relevant international standards and good practices.

The Quality Management System of CNCAN includes also a procedure for drafting regulations and a process is in place to ensure internal consultation among CNCAN departments regarding the draft regulations. This is undertaken prior to the external consultation. The aim of the internal review is to provide an independent assessment of the scope, structure, content and implications of the regulatory documents, by persons not directly involved in their elaboration. In some cases, external experts are also involved in the review the draft regulations developed by CNCAN staff. The correctness with regard to technical and legal aspects is observed.

The regulations in draft are published on the CNCAN website and are sent for external consultation to all interested organizations in order to receive feedback. The comments and suggestions received are analysed and discussed in common meetings. As a consequence of this review process, the regulations may suffer some amendments. Subsequently, the final revision of a regulation is approved by the President of CNCAN and then submitted for publication in the Official Gazette of Romania. Besides publication in the Official Gazette, in order to provide for

broader dissemination, CNCAN publishes the regulations separately in brochures, as well as on the website.

In accordance with the provisions of the Law no. 111/1996, CNCAN has the responsibility for reviewing the regulations whenever it is necessary for these to be consistent with international standards and with relevant international legislation in the domain, and for establishing the measures for the application thereof.

Various sources of information relevant for updating the system of regulations and guides are used, including the development of international safety standards, international cooperation, feedback from the operators and feedback from CNCAN inspectors based on their experience with the enforcement of the regulations.

The development of the regulatory framework is based mainly on the needs arisen from the strategy for development of nuclear field and on those arisen from the licensing process.

Besides the obligations of transposition and implementation of the European Commission regulations there are needs arisen from harmonization process in the WENRA countries. Due to CNCAN's participation in the harmonization process within the WENRA countries, the use of IAEA Safety Standards has become more systematic.

#### *Safety requirements for predisposal management*

This regulation contains safety requirements as well as licensing requirements for predisposal management of radioactive waste, disused radioactive sources and spent nuclear fuel. The regulation contains seven chapters. The regulation contains requirements for management system such as responsibilities of licensee, integrated management system, safety culture, record keeping, reporting as well as interdependences among steps of predisposal management of radioactive waste, disused sources and spent nuclear fuel. Specific requirements for each step of the predisposal management chapter details the control of generation of radioactive waste and disused radioactive sources, characterization and classification, segregation, waste acceptance criteria, treatment, conditioning and storage of radioactive waste.

The regulation details requirements for the development of predisposal radioactive waste, disused radioactive sources and spent nuclear fuel management facilities includes requirements for location and design, construction and operation. The clearance and discharge requirements are also defined.

Safety verification chapter introduced the concept of safety case and safety assessment and contains general requirements for development of these documents.

The last chapter dedicated to licensing is based on national nuclear law and it details the content of application and necessary supporting documents which have to be submitted by an applicant.

The regulation is based on the IAEA recommendations provided in the General Safety Requirements Part 5 Predisposal of Radioactive Waste as well as the Safety Reference Levels developed by the Western European Nuclear Regulators Association (WENRA) on the storage of radioactive waste and spent nuclear fuel.

#### *Safety requirements for disposal*

This regulation contains safety requirements as well as licensing requirements for disposal of radioactive waste. The scope, domain and definitions are described in first chapter. The next

chapters describe the concept of graded approach as well as the requirements for management system such as responsibilities of licensee, integrated management system, safety culture, and operational structure. Specific requirements for each step in the development of a facility such as siting, design, construction, commissioning, operation and closure are defined.

Safety verification chapter introduces the concept of safety case and safety assessment and contains general requirements for development of these documents.

The last chapter dedicated to licensing is based on national nuclear law and details the content of application and necessary supporting documents which have to be submitted by an applicant.

The regulation is based on IAEA SSR 5 Disposal of radioactive waste as well as Safety Reference Levels developed by WENRA – Waste and decommissioning Working Group.

### *Safety requirements for decommissioning*

The safety and licensing requirements on decommissioning cover both nuclear and radiological facilities. The regulation is based on the IAEA recommendations provided in General Safety Requirements Part 6 Decommissioning of Facilities, as well as on the Safety Reference Levels developed by WENRA on decommissioning. The end state criteria, responsibilities of the licensees, integrated management system, safety culture, record keeping system, reporting to CNCAN are described in this regulation. The regulation defines the requirements for decommissioning strategies, planning of decommissioning activities, as well as the transition from operation to decommissioning phase and conducting of decommissioning actions. The regulation introduces the concepts of safety case and safety assessment, their contents being provided in the Annexes to the regulation. The requirements for final radiological verification are also provided. The content of the final radiological survey report as well as the final decommissioning report are provided in the Annexes to the regulation. The licensing requirements are based on the provisions of the nuclear law.

### *Safety requirements for activities involving natural sources*

This regulation contains safety requirements as well as licensing requirements for activities involving natural sources. The regulation describes both existing exposure situations and planned exposure situations associated with natural sources. The activities and industries under the scope of the regulation are listed in an annex. An undertaking carrying out or intending to carry out any of the industrial or scientific activities specified shall determine the activity concentration of radionuclides in the uranium and thorium decay chains in all materials that are associated with that activity or have potentially elevated activity concentrations of these radionuclides.

The next step is dose evaluation when an undertaking carrying out any practice identified shall evaluate the radiation exposure of workers and members of the public. The assessment of effective doses received by workers shall take into account all activities in the practice. Special consideration should be given to maintenance and repair activities and residue management activities that may result in doses that are higher than those resulting from normal operations.

The regulation contains requirements for notification, registration and licensing of activities involving natural sources. The regulation is based on IAEA GSR 3 Radiation Protection and Safety of Radiation Sources: International Basic Safety Standards as well as other IAEA safety reports.

### *Overview of the licensing system*

The licensing process is based on the provisions of the Law and of the regulations issued by

CNCAN. The Law clearly stipulates that the prime responsibility for the safety rests with the licence holder. As required by the Law, a licence is needed for each of the stages of the life time of a nuclear installation. For a waste treatment or disposal installation, the licensing stages include, as appropriate: design, siting, construction, commissioning, operation, modification (as major upgrades), preservation and decommissioning, closure, monitoring and post-closure control.

The requirements specified in the Law and the regulations are rather general and therefore a number of mechanisms are in place to ensure effective management of the licensing process.

The detailed regulatory requirements, as well as the assessment and inspection criteria used by CNCAN in the licensing process are derived from a number of sources, such as:

- Romanian regulations;
- Limits and conditions specified in the different licences;
- IAEA safety standards and guides;
- ICRP recommendations;
- Safety related documentation produced by the licensee and approved or accepted by CNCAN (e.g. safety assessment reports, decommissioning plans, and reference documents).

Apart from the formally issued (published) regulations, the requirements established by CNCAN in the licensing process are imposed through regulatory letters. Requirements and dispositions are stated also in the inspection reports.

Control of licensing submissions is described in the Management System of CNCAN, within the framework of which a set of procedures have been established that define the different activities and tasks performed by the different organisational divisions involved in the licensing process. The licensing process is documented according to CNCAN internal procedures.

#### *Regulatory review methodologies*

In accordance with the provisions of the Law, CNCAN is empowered to request from the licensees, or from the applicants for a licence, all the documentation needed for the regulatory decision making process on safety related matters. The documentation that needs to be submitted to CNCAN for review and approval is usually specified in the regulations.

Additional support documentation is requested on a case by case basis and specified in regulatory letters, minutes of the meetings between CNCAN staff and licensee's representatives, etc.

The safety related documentation made available to CNCAN includes a large variety of documents, such as safety analysis reports, (quality) management manuals, different types of safety assessments and technical evaluations, information reports and procedures (reference documents, station instructions, operating procedures, work plans, etc.).

The methodologies describe the regulatory review and assessment process for licensing of predisposal, disposal, decommissioning and natural sources activities and facilities. The methodologies describe the regulatory review process of an application and associated technical documentation. They describe the criteria for decision making for licensing of these activities and facilities.

The methodology describes how a reviewer checks the information submitted by an applicant in order to demonstrate the compliance with regulatory requirements. For these purpose has been developed specific checklists which cover each activity and licensing step. When an application is received the reviewer checks the completeness of the application and correctness of the technical information. If the reviewer does not consider the information submitted to be adequate, it requests to update or supplement the information accordingly. After receiving the additional or updated information from the undertaking, the reviewer reviews the submission and technical documentation. If there still are inadequate information the reviewer organizes a meeting to discuss the inadequacy of information/documents and provide an explanation. After the review the reviewer develop an evaluation an assessment report describing findings, conclusions and proposals.

The comments resolution programme identifying each issue, the resolution mechanism and time frame for resolution is also included in the evaluation and assessment report.

The report includes any special conditions which need to be incorporated into the licence.

### *Regulatory inspection and enforcement*

According to the Law, the licensees and applicants have the obligation of facilitating CNCAN inspections and access to documentation and to provide all the information required by CNCAN. The inspection criteria are usually specified in the internal procedures of CNCAN. However, situations may arise for which more detailed criteria need to be established ad-hoc, with adequate justification based, as the case may be, on safety assessments, engineering judgement or recognised good practices.

The key objective of the CNCAN inspection programme is to monitor compliance with the legal, regulatory and licensing requirements, and to take enforcement action in the event of non-compliance. The inspections are planned in a systematic manner.

The inspections performed by CNCAN include:

- scheduled inspections, planned and performed either by each of the technical divisions, or jointly, with the occasion of the major licensing milestones;
- unscheduled and/or unannounced inspections, some of these being reactive inspections, in response to incidents;
- routines and daily observation activities performed by the resident inspectors.

The assessment and inspection activities performed by CNCAN staff are documented by one of the following means:

- Assessment reports;
- Inspection reports;
- Written minutes of the meetings with licensee's representatives.

In accordance with the provisions of the Law, CNCAN has in place a system to enforce compliance through graded measures. Therefore, the possible actions that CNCAN can take in the event of non-compliance are:

- dispositions for licensee action (these are stated in each inspection report);
- action notices/directives stated in regulatory letters;
- licence amendments;
- restricted operation;
- revocation or suspension of the license;
- prosecutions.

Analysing in detail the existing legislative and regulatory framework, it can be clearly seen that it provides for:

- the establishment of applicable national safety requirements and regulations for radiation safety (this is done by updating the existing system of regulations);
- a system of licensing of spent fuel and radioactive waste management activities (Law No. 111/1996 requires the licence of all nuclear activities);
- a system of prohibition of the operation of a spent fuel or radioactive waste management facility without a licence (the system of sanctions establishes penal sanctions for such situations);
- a system of appropriate control, regulatory inspection and documentation and reporting (Law No. 111/1996 establishes the regulatory inspection rules, while the regulations and licensing conditions establish the requirements for control, documentation and reporting);
- the enforcement of applicable regulations and of the terms of the licences;
- a clear allocation of responsibilities of the bodies involved in the different steps of spent fuel and of radioactive waste management.

Thus it can be concluded that the obligations under article 19 of the Joint Convention are met by Romania.

### ***E3. Regulatory authority in nuclear field (Article 20)***

#### ***E3.1. Responsibilities of National Commission for Nuclear Activities Control (CNCAN)***

According to the provisions of Law no. 111/1996, CNCAN is the regulatory body, empowered with the regulation, licensing, and control of nuclear activities.

The general responsibilities of CNCAN are stipulated in the Chapters I and V of the Law no. 111/1996, and are further detailed in the Rules for Organization and Functioning of CNCAN, approved by Governmental Decision.

The mandate of CNCAN can be summarized as follow:

- CNCAN is the national authority competent in exercising regulation, licensing and control in the nuclear field, for all the activities and installations under the scope of the Law.
- CNCAN elaborates the strategy and the policies for regulation, licensing and control with regard to nuclear safety, radiological safety, non-proliferation of nuclear weapons, physical protection of nuclear installations and materials, transport of radioactive materials and safe management of radioactive waste and spent fuel, as part of the National Strategy for the development of the nuclear sector, approved by Governmental Decision.
- CNCAN is responsible to ensure, through the regulations issued, regulatory letters and the dispositions arising from the licensing and control procedures that an adequate framework is in place for the deployment of activities under the scope of the Law.
- CNCAN is responsible for revising the regulations whenever necessary for the correlation with the international standards and ratified conventions in the nuclear field and for establishing the necessary regulatory measures for their application.



CNCAN has the following duties and responsibilities:

- Initiates projects for legislative acts in its area of competence and issues regulations in the nuclear field, consulting as necessary the other authorities with attributions in this domain, according to the Law;
- Reviews and consents to all the legislative acts with implications for the nuclear field, prior to their coming into force;
- Approves, in accordance with the Law, the intervention plans in case of nuclear accident and participates in the intervention;
- Collaborates with the central authority for environmental protection and controls the implementation of the activities of the environmental radioactivity monitoring network;
- Requests to the competent authorities in the field of national security to perform the necessary checks for the persons with responsibilities in the field of nuclear activities, in compliance with the specific regulations;
- Initiates, with the consent of the Ministry of Foreign Affairs, activities for cooperation with IAEA and with other international organisations specialised in the nuclear field;
- Initiates necessary arrangements at government level to conclude treaties in its field of competence;
- Concludes treaties at the department level in its field of competence;
- Cooperates with similar institutions/authorities from other states;
- Controls the implementation of the provisions of international treaties and agreements in force, with regard to safeguards, physical protection, illicit traffic, transport of nuclear and radioactive materials, radiation protection, quality assurance in the nuclear field, nuclear safety, safe management of spent fuel and radioactive waste, and the intervention in case of nuclear accident;
- Establishes and coordinates the national system for evidence and control of nuclear materials, the national system for evidence and control of radiation sources and of nuclear and radiological installations, and the national registry of radiation doses received by the occupationally exposed personnel;
- Cooperates with other authorities that have, according to the Law, attributions with regard to the safe operation of nuclear and radiological installations, correlated with the requirements for the protection of the environment and the population;
- Ensures public information on matters that are under the competence of CNCAN;
- Organises public debates on matters that are under the competence of CNCAN;
- Represents the national point of contact for nuclear safeguards, for the physical protection of nuclear and radiological materials and installations, for the prevention and combating of the illicit traffic of nuclear and radioactive materials, and for nuclear and radiological emergencies;
- Orders the recovery of orphan sources and coordinates the recovery activities;
- Licences the execution of nuclear constructions and exercises control over the quality of constructions for nuclear installations;
- Carries out any other duties stipulated by the Law, with regard to the regulation and control of nuclear activities.
- Transmits notifications and presents reports to the European Commission on the status of the implementation of the Council Directives;
- Approves the national strategies for the development of the nuclear sector and for the safe management of the spent nuclear fuel and of the radioactive waste;

- Organizes periodically, at least once every 10 years, self-assessments and international peer-reviews of its activities, as well as of the national regulatory framework.

### ***E3.2 Position of CNCAN in the Government Structure***

CNCAN reports to the Prime Minister, through the General Secretary of the Government. CNCAN is completely separated and independent from all the organisations concerned in the promotion or utilization of nuclear energy. The responsibilities assigned to CNCAN by the Law no. 111/1996 are concerning solely the regulation, licensing and control of nuclear activities.

CNCAN exercises its functions independently from the ministries and other authorities of the central public administration, subordinated to the Government. The companies and organisations that operate or own the main nuclear and radiological installations are subordinated to the Ministry of Energy, Ministry of Economy or to the Ministry of National Education.

CNCAN is chaired by a President nominated by the Prime Minister. The position of the CNCAN President is assimilated to that of a State Secretary. The President of CNCAN, with the advice of the General Secretariat of the Government, organises the subsidiary structures of the divisions of CNCAN depending on actual needs and conditions of the activities of CNCAN. The organisational structure of CNCAN and the modifications thereof are approved by Governmental Decision.

### ***E3.3 CNCAN Organisational Structure and Human and Financial Resources***

The current organisational structure of CNCAN is shown in Fig. E.2

CNCAN staff evaluates and processes applications for CNCAN licences; develops and prepares licensing recommendations; administers CNCAN policies and procedures; monitors, audits and inspects nuclear facilities and activities; drafts and administers licenses; evaluates the qualifications and performance of licensees and their staff; prepares documents and reports; reviews reports and records; develops and enforces regulatory standards and requirements.

The division in charge of the regulation, licensing and control of nuclear installations, including CNE Cernavoda, is the Nuclear Fuel Cycle Division, composed of the following units:

- Nuclear Safety Assessment Unit;
- Nuclear Regulations and Standards Unit;
- CNE Cernavoda Residents Inspectors Unit;
- Management Systems Oversight Unit;
- Radiological Protection, Radioactive Waste Safety and Transport Unit;
- Radiological Emergencies Unit;
- Mining, Safeguards and Physical Protection Unit.

There are currently 32 staff members working in the Nuclear Fuel Cycle Division of CNCAN.

The division in charge of the regulation and licensing of radiological installations and sources is the Radiological Installations and Sources Licensing Division, composed of the following units:

- Medical Installations Licensing Unit;
- Industrial Installations Licensing Unit;
- Sources and Dose Registry Unit.

The National Dose Registry as well as the National Radiation Sources Registry are managed by CNCAN through Radiological Installations and Sources Licensing Division.

The division in charge of the control of radiological installations and sources is the Radiological Installations and Sources Inspection Division. This division is organized to cover 4 regions in the country:

- Inspection Unit Zone 1 - Moldova;
- Inspection Unit Zone 1 - Muntenia;
- Inspection Unit Zone 1 - Transilvania;
- Inspection Unit Zone 1 – Bucuresti-Ilfov.

In specific cases, external consultants are also employed to assist CNCAN staff in review and assessment activities or in the development of regulations. In addition, CNCAN benefits from external expertise through IAEA technical co-operation projects and bilateral agreements.

CNCAN has plans to increase the number of its technical staff in order to be able to improve the regulatory framework and processes, in line with the best international practices.

The most important challenge in recruiting and retaining suitably qualified personnel is represented by the current level of the salaries of CNCAN staff (the salaries in the regulatory authority are significantly lower than the salaries offered by the industry or by international organizations). CNCAN has informed the Government on both these issues and has requested measures to be taken. The transfer of knowledge from the existing experts to the new comers is continuously organized.

As regards the funding, before November 2009, CNCAN collected money for its budget from fees charged to carry out inspection activities and technical assessments and for granting licences, permits and authorisations and was self-funded. Since November 2009, all the money collected from fees and tariffs for CNCAN activities became revenues to the state budget and CNCAN is currently funded from the state budget through the General Secretariat of the Government (SGG).

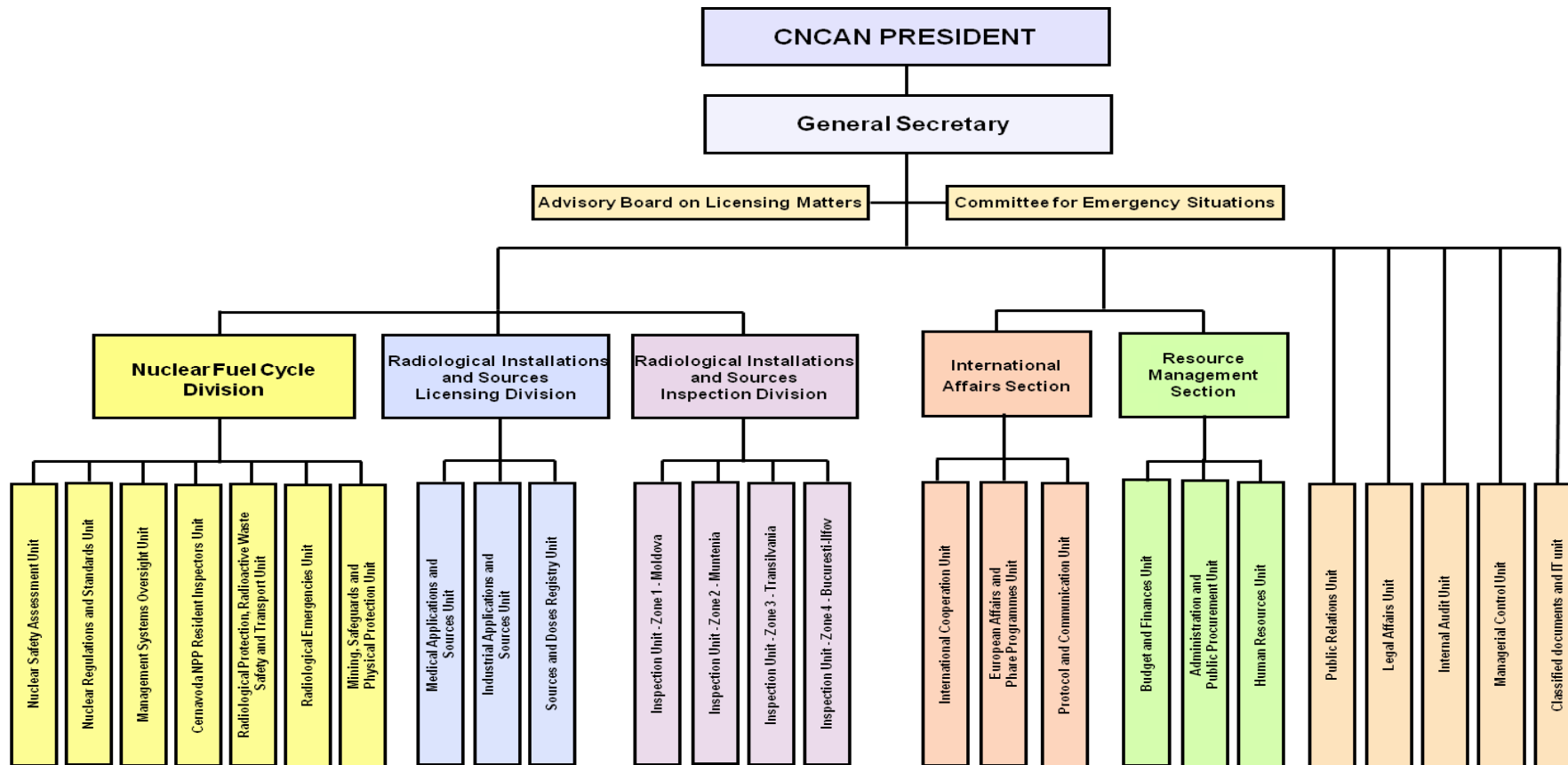

**Figure E2: The organizational chart of CNCAN**

#### ***E4. Other Governmental Authorities***

***The Ministry of the Environment*** is the central authority for environmental protection and has specific responsibilities in the licensing and control of nuclear installations. The main responsibilities of the central authority for environmental protection are to:

- organize, under the law, the environmental radioactivity surveillance network on the territory of Romania, providing the necessary information flow for the integrated monitoring system of the environmental parameters.
- issue the environmental agreements and licence on the basis of criteria provided by law
- notify CNCAN and the Ministry of Internal Affairs on its findings from the monitoring activity exercised by it, and to collaborate with them in order to set up the necessary measures to be taken.

The environmental agreement issued by the central authority for environmental protection is a prerequisite for the issuance of the siting licence by CNCAN for a nuclear installation.

The environmental licence shall be issued by the central authority for environmental protection after CNCAN issues the trial run or operation licence for a nuclear installation.

***The Ministry of Health*** is the central authority for public health. The main responsibilities of the Ministry of Health are to:

- authorize the introduction into the social and economic circuit, for utilization or consumption purposes by the population, of products that were subject to irradiation or which contain radioactive materials;
- authorize the introduction into the medical field, for medical treatment and diagnosis purposes, of sealed or unsealed sources, of ionizing radiation generating devices, and of pharmaceutical products containing radioactive materials;
- develop its own licensing and control regulation;
- organise the monitoring network of the contamination with radioactive materials of foodstuff, over the whole food chain, drinking water inclusive, as well as of other goods destined to be used by the population, according to the law.
- organise the epidemiological monitoring system of the health condition of the occupationally exposed workers, and of the hygiene conditions in units in which nuclear activities are carried out.

***The Ministry of Internal Affairs*** through the General Inspectorate for Emergency Situations in co-operation with all specialized bodies of the central and local public administration coordinates the preparedness and response in case of nuclear accident, in compliance with the provisions of the law.

#### ***The Ministry of Energy***

The energy sector is under the supervision of the Ministry of Energy, which formulates policies and strategies. The Ministry of Energy establishes the national strategy in the energy field and is the major shareholder of the nuclear energy production sector, nuclear research and engineering, nuclear fuel and heavy water production.

The energy strategy defines the main objectives of the electricity sector on a medium and long term and the most effective ways to reach them, aiming to ensure the sustainable development of the national economy and to assure the energy needs and a civilised living standard both today and on the long term, at affordable prices. The energy strategy is produced by the Ministry of Energy, under extended consultation with the energy industry, NGOs, business environment and other relevant stakeholders.

The energy policy follows the guidelines established by the energy strategy and is elaborated also by the Ministry of Energy, in lines with the Governing Program, for a medium term, and taking into consideration possible long term developments, focusing mainly on: the development of the institutional and legislative framework; ensure energy security and the legal framework for safe and stable operation of the national energy system; ensure environment protection; ensure transparency of prices and of tariffs for fuels and electricity; increase efficiency related to the use of fuel and energy; participation to the regional and internal energy markets, develop international cooperation in the energy field.

***The Ministry of the Economy*** is the central authority that applies the Government strategy and programme in the economy, industrial policies and competitiveness fields of activities. The Ministry of Economy has responsibilities in the energy transport and also in the achievement of the National Plan for Waste Management generated by the industry.

***The Nuclear Agency and for Radioactive Waste (ANDR)***, subordinated to the Ministry of Economy is responsible for:

- the preparation and periodic revision (at least once every five years) of the National Strategy for spent fuel and radioactive waste management, in collaboration with licence holders, and for monitoring its implementation;
- planning, implementing and reporting the National Programme, including disposal of spent fuel and radioactive waste,
- the disposal of the spent fuel and radioactive waste and resulting from the operations and decommission of nuclear and radiological facilities
- coordination the pre-disposal of spent fuel and radioactive waste from operations and decommissioning activities
- establishment and maintenance of a national inventory of spent fuel and radioactive waste;
- promoting the R&D programmes necessary to implement the National Programme, and benefits from the results of those programmes;
- recovery, treatment and disposal of orphan sources, historic wastes resulting from past practices, and wastes resulting from accidents or nuclear incidents;
- management and disposal of radioactive wastes and radiation sources, including the decommissioning of their nuclear installations, in cases where an operator is bankrupt, in liquidation or their financial resources resulting from judicial liquidation are insufficient;
- management of the financial resources (national funds) to cover the full costs for disposal of all spent fuel and radioactive waste - this includes periodically updating the cost estimates, and ensuring adequate funds will be available.

***The State Inspectorate for Boilers, Pressure Vessels and Hoisting Installations (ISCIR)***, subordinated to the Ministry of Economy, is responsible for the licensing and control of the pressure systems and equipment, including those used in nuclear and radiological installations, with appropriate consultation and collaboration with CNCAN.

### ***E5. Cooperation with other governmental authorities***

The licensing system is administered by CNCAN in cooperation with other governmental authorities (ministries and agencies) in such areas as environment, health, transport, labour, security, etc. The issues raised by these authorities are taken into account before licences are issued by CNCAN, providing that there is no conflict with the provisions of the Law and of the CNCAN regulations. All other licences granted by other governmental authorities are prerequisites to the CNCAN licences. An exception would be the environmental authorisation issued by the Ministry of Environment after the issuance of the operation licence by CNCAN. The environmental agreement, issued by the same Ministry is however a prerequisite to the siting licence issued by CNCAN.

The Law no. 111/1996 gives a list of authorities having attributions in controlling various aspects related to nuclear activities. Although their attributions and responsibilities are established by the legislation in force, CNCAN has also signed formal Memoranda of Understanding with each of these organisations, for ensuring the prevention of potential gaps and overlaps in the implementation of their respective duties and responsibilities. The responsibilities and attributions of the other authorities empowered by the Law to control specific activities in the nuclear field have been described in detail in the previous report and have remained unchanged.

For ensuring transparency of its activities and decision making process, CNCAN routinely consults with and ensures information of all the organisations that have an interest in its regulatory activities, including licensees and other nuclear industry representatives, governmental, local and municipal authorities, departments and agencies as well as interest groups and individual members of the public.

### ***E6. Independence of Regulatory Authority in nuclear field***

According to the Law no. 111/1996, CNCAN is regulatory body for nuclear activities.

CNCAN exercises its functions independently from the ministries and other authorities of the central administration, being subordinate to the Government.

The general attributions and responsibilities of CNCAN are stipulated in the Law no. 111/1996, and are further detailed in the Regulation for Organisation and Functioning of CNCAN, approved by Governmental Decision.

CNCAN reports annually, and whenever is requested, to the Prime Minister, through the General Secretariat of the Government, on the status of the regulation, licensing and control activities. In addition, whenever the situation requires, CNCAN presents reports on:

- Events that may affect the safe operation of nuclear facilities.
- Situations that may affect national interests or the radiological protection of population and environment on the Romanian territory.

For ensuring transparency of its activities and decision making process, CNCAN routinely consults with and ensures information of all the organisations that have an interest in its regulatory activities, including licensees and other nuclear industry representatives, governmental, local and municipal authorities, departments and agencies as well as interest groups and individual members of the public.

## **SECTION F. OTHER GENERAL SAFETY PROVISIONS**

### ***F1. Responsibility of the license holder (Article 21)***

According to the Law no.111/1996, the prime responsibility for the safety of a nuclear or radiological installation rests with the licence holder. This general responsibility includes the responsibility for the management of the spent fuel and of the radioactive waste generated within the practice, and the responsibility for decommissioning of the facility. The main responsibilities of the licence holder for any spent fuel or radioactive waste management facility are the following:

- to ensure and maintain nuclear safety, protection against ionizing radiation, physical protection, emergency plans in case of nuclear accidents, quality assurance for the licensed activities, and records of nuclear and radioactive materials;
- observance of the technical conditions and limits included in the licence and reporting of any violation, in accordance with specific regulations;
- development of its own system of requirements, regulations, and instructions ensuring the implementation of the licensed activities without any kind of unacceptable risks ;
- to bear the expenses related to the collection, handling, transport, treatment, conditioning, storage and disposal of its wastes;
- to bear the expenses related to the decommissioning of its nuclear or radiological facility;
- to ensure adequate staff to carry out the licensed activities.

CNCAN carries out preventive and operative control on the observance of laws and regulations, at the licence holder's facilities. Any failure of the licence holder in the compliance of the requirements is followed by corrective actions, which may include sanctions or even licence suspension.

Other means to ensure that the licence holder meets its responsibilities is the reporting system. For CNE Cernavoda, CNCAN includes specific reporting requirements in each licence, such as:

- Quarterly Reports;
- Environmental Monitoring Reports;
- Event Assessment Reports;
- Reliability Reports.

Similar requirements regarding operation annual report, environmental monitoring annual reports and event assessment reports are established by CNCAN for the research reactors, including their spent fuel management facilities, for the Nuclear Fuel Plant and for the radioactive waste management facilities. For CNU Feldioara Subsidiary and for the uranium mining activities, CNCAN requires annual reports for radiation protection, radioactive waste management and for the environmental monitoring.

According to the Governmental Ordinance no.11/2003 in case that a licensee ceases to exist legally, or is unable to continue its activity, the responsibility for the spent fuel and radioactive waste management as well as the responsibility for the facility decommissioning rests with ANDR, till a new licence holder is established.



According to the Fundamental Regulations on the Radiological Safety, for the past activities that have generated contamination or radioactive waste, CNCAN can impose intervention measures. The owner of the site has the responsibility to implement these measures.

## ***F2. Human and financial resources (Article 22)***

According to the Romanian Law no.111/1996 the licence for any facility is granted only if the applicant meets the following requirements:

- proves the professional qualification for each position of its staff;
- has insurance or any other financial guarantee to cover his responsibility for nuclear damages;
- has financial arrangements for safe management of its own radioactive wastes and for decommissioning of its installation.

The law mentioned above imposed a system of individual permits for each person employed for works with radioactive materials or in radiation fields. The permits are issued based on training and examination by the competent authorities or, by licensee, as approved by CNCAN.

The Final Safety Analysis Report for CNE Cernavoda Unit 1 and Unit 2 which are periodically updated during plant lifetime must contain special provisions with respect to plant organizational structure, experience and training for the key plant personnel, assurance that minimum plant complement (operations, technical, maintenance, etc.) is always in place; the plant training programs are also extensively assessed by CNCAN through periodic audits.

Adequate human and financial resources to support the plant safety are prerequisites to obtain and maintain the operating licence.

Similar requirements for getting an operation licence are established by CNCAN for reactors and for other facilities, including spent fuel and radioactive waste management facilities.

In addition, CNE Cernavoda has to pay yearly legal contributions to the Fund earmarked for management of radioactive waste and to the Fund for decommissioning of nuclear installations. This contribution shall be paid for each unit.

The small producers pay to IFIN HH or ICN for the services including disposal.

### ***F2.1. Qualified staff availability as needed for safety related activities during the operating lifetime of a spent fuel and radioactive waste management facility***

Romania has taken contact with Nuclear Technology before starting construction of its first nuclear power plant, and regulations related to staff Training and Qualification have been in place since 1975.

When Romania bought the CANDU technology, the training issue had been considered since the early phase of the contract negotiations. The initial training for management, operation, and technical maintenance key personnel was provided in Canada. Around 100 persons were trained in an operational CANDU-600 MW in Canada prior to be assigned to any commissioning/operation activities, in order to allow them to fulfill their position responsibilities safely, effectively and efficiently.

Together with technical design Romania has bought the NPP personnel training concept and training and qualification programs for licensed / non-licensed operation staff, technical, maintenance and training staff as well. These programs have been adopted but continuously adapted based on IAEA Guides related to NPP Personnel Training and Qualification, and INPO/WANO recommendations related to Training Programs -Development. In this way the Systematic Approach to Training (SAT) has been implemented in CNE Cernavoda training activities. Reference Documents as Station Instructions and Internal Department Procedures have been put in place to establish a structural Training Concept for NPP Personnel.

However, because the organizational structure and position responsibilities at Romanian NPP are similar to those used at other CANDU stations, training needs derived from these functions have been used to prepare standard training programs and courses.

In addition, each NPP department performed a job and task analysis, identifying training needs required for effective job performance (the first SAT stage – Analyses).

Each NPP department must document its training needs by preparing a generic Job Related Training Requirements (JRTR) for each position, or group of similar positions. At this time any training program in the plant is based on positions JRTR's. The technical engineering may be considered an exception from the above. For each technical engineer is prepared a Qualification Guide which contains the training and qualification requirements for its duty areas.

Training Objectives for each Training program have been produced by application of the second stage (Design) of the SAT system. The third SAT stage has been applied (Development) and training materials have been produced, based on previous determined training objectives.

Having the JRTR's and Qualification Guides for each position, the training objectives have been established and the training materials developed. Based on this, it was possible to design and implement a career path for main positions. Based on generic JRTR of each chart organization position, a Training Qualification Index (TQI) can be calculated for each individual. The individual TQI is a performance evaluation criteria so all departments have the TQI value for a certain period of time as performance indicator.

A system of Individual Performance Evaluation has been put in place mostly for Personnel Performances Annual Evaluation. A better system for Training Effectiveness and Personnel Performance Evaluation at the work place is going to be established, based on the last recommendations and theories.

CNE Cernavoda has developed activities related to Safety Culture continual improvement and self-assessment of safety culture starting with 2006. An overall safety culture framework was adopted, in the form of a model and a set of observable characteristics which guide the organization in its work as well as provide a basis for safety culture assessment tools. The framework structure is derived from Edgar Schein's 3-element model of culture (basic assumptions, espoused values (i.e. principles) and artefacts) which is recommended as a base by the IAEA. The safety culture framework incorporates the IAEA characteristics, and insights from other sources like INPO. The safety culture framework is sustained by a safety culture management model, which describe the management activities which are developed to sustain and grow nuclear safety.

Based on this framework, safety culture surveys were started since 2006, complemented by other methods of assessment like staff interviews and analysis of records. The assessment process is described in Plant Self-assessment manual (and correspondent work procedures) and it is performed yearly. Results are discussed in management meetings and management improvement initiatives were driven by the insights of the safety culture self-assessments, in areas like communications or personnel motivation. Based on the survey's results, CNE Cernavoda personnel has a high respect for safety, understand their roles and responsibilities and safety requirements and procedures are followed.

In addition to standard training described above, a non-standard training is considered for NPP personnel qualification. In this category is included the personnel training through the co-operation with other organization (IAEA, WANO, COG, Suppliers etc.). This is a very important part of key personnel development through courses, fellowships, workshop participation, and development programs participation, organized and sponsored by above-mentioned organization. Co-operation with these organizations didn't mean only participation of Romanian personnel in abroad training activities but also organizing courses in Romania.

In order to support the internal and external training activities and to ensure continue SAT application a Training Organization has been established and a Training Center has been constructed.

CNCAN is closely supervising the training activity in the plant. It is involved not only in the licensed staff training and evaluation process but also in other staff training and plant training policy as well. In this respect CNCAN is periodically auditing plant training activity and it is directly involved in the licensing training programs approval and evaluation.

CNCAN ensures that the utility allows only high qualified, competent staff to perform the following functions and tasks which are critical to nuclear safety:

- Recognize if a proposed action (or any changes to equipment, procedures or staffing) is threatening a layer of defense;
- Monitor, operate and maintain safety and safety related systems;
- Identify incipient equipment failures, so that corrective action can be taken;
- Properly execute emergency response procedures to mitigate and accommodate consequences of potential accidents.

Based on the qualification, training and retraining requirements for all operation positions, CNCAN required a similar training approach for the individuals performing tasks critical to nuclear safety and belonging to other plants' departments such as Station Health Physics, Station Engineering Support, and Maintenance Support etc. These positions also have detailed qualification, training and retraining requirements, according to their duties.

Management Personnel must also be licensed by CNCAN before they are fully appointed to the job, as follows:

- Station Manager
- Production Manager
- Technical Manager
- Health Physics Senior Superintendent
- Operation Senior Superintendent (Unit 1 and Unit 2)

- Safety and Compliance Senior Superintendent
- Training Senior Superintendent
- Quality Assurance Senior Superintendent

Continuing training and retraining for any chart organization position is also established. Refreshing training for any chart organization position is also established or at least is counted that is necessary to be established. At this time refreshing training is for sure established for Licensed Operation Staff. The other personnel are in general under continuous training to get their 100% qualification. Retraining for special skills or abilities is established and done as required.

The shift supervisors (i.e. main reactor operators), reactor operators and the senior staff with responsibilities in radiation protection (i.e. the qualified experts) have to pass a CNCAN examination in order to receive the permit to operate the reactor, respectively the practice permit. Finally it could be considered that CNE Cernavoda has the nuclear worldwide accepted training approaches and standards, ensuring a qualified, competent staff for CNE Cernavoda operation and maintenance.

Regarding the research reactors, a training system that assures the safe management of reactors operation, including spent fuel management, is in place. The reactor main operators and operators, and the staff with responsibilities related to radiation protection, including the qualified experts, are tested by CNCAN, in order to get the permit to operate the reactor, respectively the practice permit.

For all other facilities, the qualified experts and the staff with responsibilities related to radiation protection have to be trained and retrained within approved by CNCAN training programs and have to pass CNCAN examination in order to get the practice permit.

### ***F2.2. Financial resources for operation of spent fuel and radioactive waste management facilities***

At CNE Cernavoda, the costs of current spent fuel and radioactive waste management activities including the costs associated with the commissioning of the Intermediate Spent Fuel Dry Storage Facility are included in the CNE Cernavoda operational costs.

The amount of the contributions which must be paid yearly by the SNN / CNE Cernavoda for decommissioning of nuclear facilities and for long term management of spent nuclear fuel and radioactive waste is determined as follows:

a) By multiplying the net quantity of electricity expected to be produced by each nuclear unit in the next year with a tariff of 0.60 euro / MWh, for establishing the financial resources necessary for the decommissioning of each nuclear unit;

b) By multiplying the net quantity of electricity expected to be produced by each nuclear unit in the next year with a tariff of 1.40 euro / MWh, for establishing the financial resources necessary for the siting, design, construction, commissioning, operation and maintenance, upgrading, closure and post closure monitoring of final repositories for radioactive waste generated by the operation of the nuclear units, for research and development activities to support the final disposal activities and for the current and capital expenditure of ANDR, according to annual revenue and expenditures approved by law.

The financial resources for operation, maintenance, upgrading, closure and post closure monitoring of DNDR Baita Bihor, decommissioning of research reactors and management of the non fuel cycle radioactive waste, in present they are assured from:

- the state budget ;
- economic contracts with radioactive waste producers from all over the Romanian territory.

Research activities related to radioactive waste management and decommissioning are supported under scientific research projects obtained in national and international competitions.

### ***F2.3. Financial provision for institutional controls and monitoring arrangements after closure of disposal facility***

The financial provisions for institutional control as well as for monitoring arrangements shall be included in the financial resources needed for final disposal of radioactive waste.

### ***F3. Quality assurance (Article 23)***

The Romanian regulation on the general requirements for Quality Management Systems (QMS) applied to the realization, operation and decommissioning of nuclear installations”, approved by the CNCAN Order No. 66/2003, requires that the owner of a nuclear facility shall establish, develop and maintain a quality management system for all phases of the lifecycle of the nuclear installation. This requirement is based on the articles 18 m) and 24 of the Law No. 111 / 1996.

In 2003 CNCAN developed a set of 12 regulations establishing the requirements on the quality management systems as licensing and general requirements, and on specific activities as siting, design, research and development, procurement, manufacturing, construction-erection, commissioning, operation, decommissioning and development and use of software products in nuclear field. In 2005 this set of regulations was completed with the thirteenth, the regulation establishing classes for the gradual implementation of the quality management system requirements in making products and services for nuclear facilities.

The current Romanian regulations on quality management systems for nuclear installations and activities have been developed by CNCAN based on the Canadian Standards series N286 ed. 95 and Z299 ed. 85, ISO 9000/2000, IAEA 50-C/Q SG and the drafts of GS-R-3 and GS-G-3.1 (DS-338 and DS-339 from 2003).

Complying with these requirements, CNE Cernavoda, FCN Pitesti, ICN Pitesti, IFIN – HH, and CNU – Feldioara Subsidiary have established and implemented Quality Management Systems in their facilities. These systems are in fact Integrated Management Systems, which integrate the provisions related to radioactive waste management, emergency preparedness, radiological protection, safeguards, nuclear safety, and physical protection, and the entire range on interaction between them at individual and organizational level, an entity that has to ensure the promotion of safety culture.

The main participants and contractors involved in the development of a nuclear facility shall have implemented a quality management system licensed in accordance with CNCAN regulations.

According to specific requirements for the quality management systems for operation of nuclear facilities the responsible organization shall perform the control of radioactive contamination in order to prevent its spreading and to implement an effective contamination monitoring system.

The responsible organization for the operation shall control the activities related to the handling and storage of the liquid and solid contaminated waste and shall ensure the measures required to maintain to the minimum the volume of radioactive waste.

All organizations involved in the realization project of the nuclear facility shall have a licensed management system for the activities in their field of responsibility. All organizations shall have implemented their own management system, which will be applied during performance of the activities. The management system is designed to satisfy all requirements of radiological safety of the facility, in all phases of the project. All required procedures shall be developed by the involved organizations and properly documented, for each activity. Some of the procedures shall be approved by CNCAN and periodically revised.

The owner have to define the requirements and responsibilities for a program of inspection which provides assurance that fabrication, installation, modification, and repair activities affecting safety-related components, systems, and structures are carried out according to the applicable specifications, instructions, procedures, drawings, or other pertinent technical requirements. The independent or regulatory quality inspections are not intended to diminish the responsibility for the quality of the work of personnel which performs the activities.

In order to ensure safe and reliable operation, programs of inspections have to be established at the spent fuel and waste management facilities, which include the following provisions:

- a. The requirements for inspections are identified and documented based on procedures, instructions, drawings, and other documents for an activity prior to the start of the activity.
- b. Inspections are accomplished in accordance with a combination of approved procedures and instructions.

Operating organization shall prepare a programme for maintenance of the waste disposal facility that is in line with the type of facility. Also, the owner shall establish and implement a programme for the surveillance of the facility as necessary and feasible.

Records should be created and maintained as to describe the history of the waste disposal facility and related activities. The owner shall ensure that records are maintained for a period of time for which the waste disposed of is considered to be an issue for safety. The records shall be stored in a manner that minimizes the likelihood of loss, damage or deterioration.

#### ***F4. Operational radiation protection (Article 24)***

##### ***F4.1. Exposures of workers and public***

###### ***F4.1.1. Optimization of exposures***

For operational radiation protection CNCAN issued the Fundamentals Regulations on the Radiological Safety approved by the CNCAN Order No. 14/2000. This regulation is a Romanian transposition of the Council Directive 96/29/EURATOM laying down basic safety standards for the protection of the health of workers and general public against the danger arising from ionizing radiation.

The Council Directive 2013/59/Euratom of 5 December 2013 laying down basic safety standards for protection against the dangers arising from exposure to ionising radiation, and repealing Directives 89/618/Euratom, 90/641/Euratom, 96/29/Euratom, 97/43/Euratom and

2003/122/Euratom, known as European BSS, shall be transposed into Romanian Legal and regulatory framework.

CNCAN is the main authority responsible with transposition and implementation of Council Directive 2013/59/EURATOM. The implementation of the provisions of this directive involves more authorities such as Ministry of Health, Ministry of Interior, Ministry of Economy and Ministry of Energy as well as Ministry of Regional Development, Public Administration and European Funds.

The transposition and implementation of the provision of this directive involves the revision of the existing legal and regulatory framework and for new aspects elaboration of new pieces of legislation. The transposition started with the revision of nuclear act Law 111/1996 on the safe deployment, regulation, licensing and control of nuclear activities. In parallel, a governmental decision on the radiological safety aspects as well as one dealing with the radon national action plan has been drafted. For specific aspects, each authority involved is still working for transposing them into national regulatory framework.

The transposition process started with the revision of Law 111/1996 on the safe deployment, regulation, licensing and control of nuclear activities. The scope of the law has been extended for all exposure situations. The main modifications of the law refer to the responsibilities in the application of Council Directive provisions. The law details the concept of regulatory control, introduces the obligation to develop and implement strategies on the management of existing exposure situation as well as on the emergency exposure situation.

The radiological safety requirements on dose limits, dose constraints and reference levels, education and training, regulatory control, occupational exposure, public exposure, medical exposure, control of high activity sources and orphan sources and inspections have been drafted into a governmental decision. It details requirements on existing exposure situation and emergency exposure situation. The provisions of the recognition of experts and services are also included.

With the support of other institutions with responsibilities in the implementation of National Action Plan to address long-term risks from radon exposures, a Governmental Decision has been drafted. The document defines the obligation of counties local authorities to perform concentration measurements of radon in doors. The reporting of the results shall be done by qualified laboratories to CNCAN. CNCAN shall developed requirements for measures, qualification and reporting of results. The employers with workplaces underground on ground have the obligation to determine the radon concentration and to take all necessary measures to reduce the level of radon indoors and to workplaces. The National Action Plan to address long-term risks from radon exposures shall be coordinated by CNCAN.

The secondary legislation regarding dosimetry, authorization procedures, training, qualifying and certification of personal, emergency preparedness and natural sources is under revision, its adopting depends on approving in Parliament of the nuclear act.

The operators have developed policies, regulations and procedures for operational radiation protection, based on Romanian regulations and ICRP / IAEA recommendations. The policy of these licensees is to keep the radiation exposure of workers and the public as low as reasonable achievable.

#### ***F4.1.2. Exposure limits***

The legal effective dose limits for the workers and for the public are 20 mSv / year and 1 mSv / year, respectively. In order to minimize the exposure, the operators have to optimize the doses and to develop processes for dose control for radiation workers, using special work plans and procedures for high hazard works.

#### ***F4.1.3. Control of releases***

CNE Cernavoda, FCN Pitesti, IFIN-HH and ICN Pitesti have implemented procedures to control the gaseous and liquid releases to the environment, based on derived emission limits approved by CNCAN.

CNE Cernavoda, FCN Pitesti, IFIN-HH and ICN Pitesti have implemented procedures to control the solid unconditional and conditional releases based on approved clearance methodology.

The unconditional release levels are established by CNCAN, for most of the radionuclides, in the CNCAN Order No. 62/2004.

CNE Cernavoda, IFIN-HH and ICN Pitesti operate testing laboratories for radiological characterization of materials for clearance as well as for operational classification of radioactive waste. The management system and analytical competences of the laboratories meet the requirements of ISO 17025, as proven by the CNCAN notifications.

CNE Cernavoda, IFIN-HH and ICN Pitesti have established environmental monitoring programs, in order to assess the effect of their activities on the environment.

#### ***F4.2. Discharges***

##### ***F4.2.1. Optimization of discharges***

According to the Fundamentals Regulations on the Radiological Safety, approved by the CNCAN Order No. 14/2000, the derived emissions limits (DELs) approved by CNCAN shall be used to quantify the relationship between releases of radioactivity and doses to critical groups from the public.

##### ***F4.2.2. Limitation of doses in normal operation***

According to the Fundamentals Regulations on the Radiological Safety approved by the CNCAN Order No. 14/2000, CNCAN shall establish in the licensing process the dose constraints of activities. The operators shall assure that the exposure limits are controlled during normal operation. For the public doses, CNCAN has established dose constraints for licensed activities in the range of 0.1-0.3 mSv/year for the member of critical groups.

#### ***F4.3. Uncontrolled releases and mitigation of consequences of unplanned and uncontrolled releases***



In order to control the release, design features and emergency procedures are in place, according to the provisions of the laws and regulations.

According to the provisions of Law no.703 / 2001 on civil liability for nuclear damages, the licence holder for a nuclear installation shall have an insurance policy covering the nuclear damages. This assures that in case of an unplanned or uncontrolled release funds are available for mitigate the effects.

### ***F5.Emergency preparedness (Article 25)***

#### ***F5.1. Legal requirements for on-site and off-site emergency preparedness***

Emergency preparedness and response in Romania is organised according to the Law 15/2005 for the approval of the Governmental Ordinance no. 21/2004, regarding the National System for the Management of Emergencies and in the nuclear/radiological emergency field according to the Law 111/1996. Other applicable regulations are mentioned as follows:

- Governmental Decision no. 1489/2004 regarding the organising and functioning of the National Committee for Emergencies;
- Governmental Decision no. 1491/2004 for the approval of the frame Regulation on the structure, attributions, functioning and endowment of the committees and operative centres for emergencies;
- Governmental Decision no. 1492/2004 on the organisational and functioning principles and attributions of the professional emergency services;
- Governmental Decision no. 2288/2004 for the approval of the nomination of the main support functions which the ministries, state authorities and non-governmental organisations have to perform in order to prevent and manage emergency situations.
- Governmental Ordinance no. 1/2014 regarding the modifying and updating the Governmental Ordinance no. 21/2004
- Governmental Decision no. 94/2014 regarding the organising, functioning and the structure of the National Committee for Special Emergencies.

Specific Regulations are in place in the field of radiation emergency preparedness and response:

- Nuclear Safety Requirements on Emergency Plans, Preparedness and Intervention for Nuclear Accidents and Radiological Emergencies, approved by Ministerial Order No. 242/1993;
- Fundamental Regulation on Radiological Safety, approved by CNCAN Order No. 14/2000;
- Regulations concerning the planning and preparation of the licensee for nuclear or radiological emergency intervention, approved by CNCAN Order No. 69/ 2014;
- Governmental Decree 223/1990 for the Romania's accession to the IAEA's Conventions on Early Notification of a Nuclear Accident and on Assistance in the Case of a Nuclear Accident or Radiological Emergency;
- Bilateral early notification agreements with Bulgaria, Greece, Hungary, Slovakia, Russian Federation, Turkey and Ukraine.

According to the Governmental Ordinance no. 21/2004, the National System for the Management of Emergencies consists of three types of structures:

- the decisional structure – committees for emergencies,
- the executive structure – general inspectorate for emergencies , and
- the operational structure – operative centers for emergencies.

All the decisional, executive and operational structures are established on three levels: national, county and local. A scheme of the National System for the Management of Nuclear and Radiological Emergencies is shown in Figure F.1.

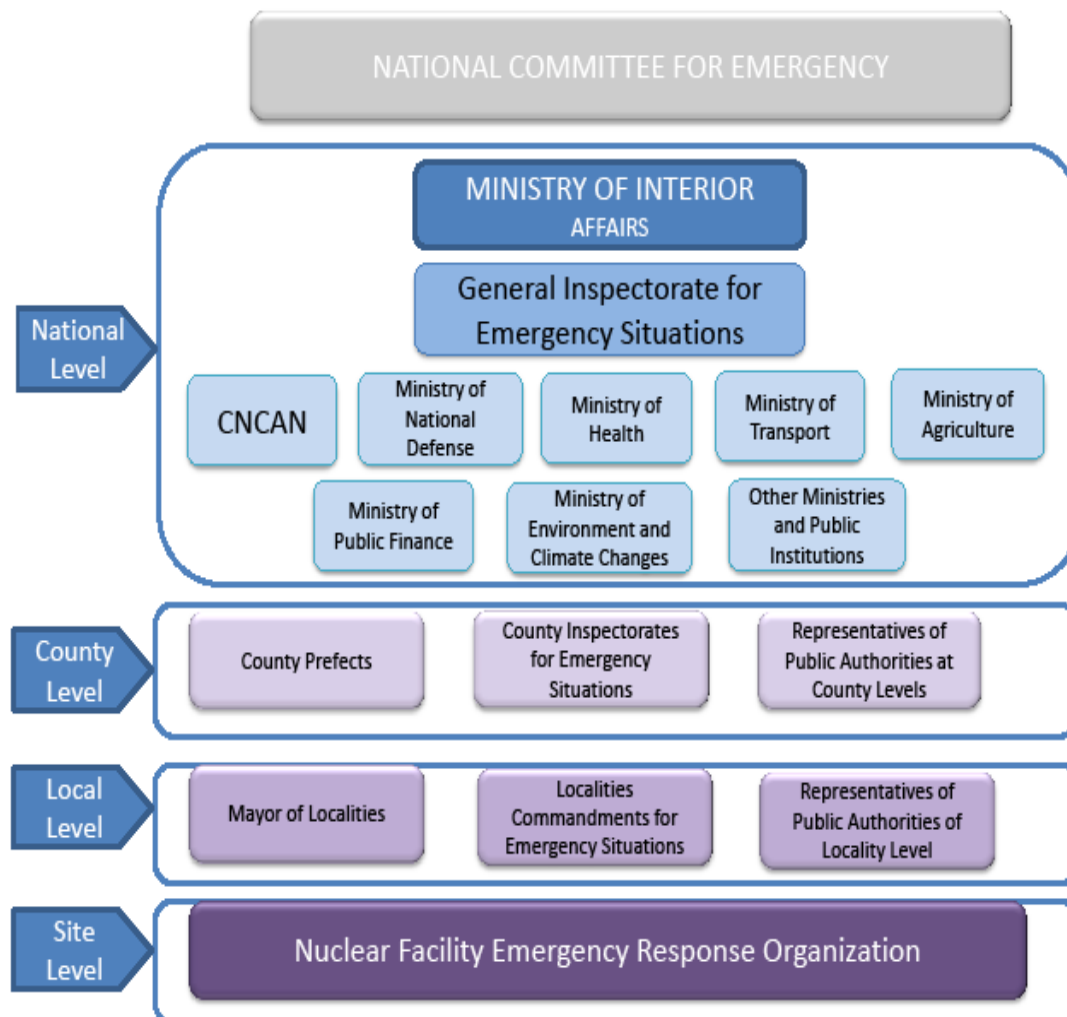

**Figure F1. The National System for the Management of Nuclear and Radiological Emergencies**

By law, the Ministry of Internal Affairs (MAI) is responsible for the management of nuclear and radiological emergencies.

***F5.2. Planning for radiation emergencies in the vicinity of Romanian territory***

Romania is a signatory of the following international emergency response agreements:

- Convention on Early Notification of a Nuclear Accident
- Convention on Assistance in the Case of a Nuclear Accident or Radiological Emergency
- Convention Regarding the Liability for Nuclear Damages.

Concerning the liaison across national borders, Romania has signed the Agreements for Early Notification of Nuclear Accidents with Russian Federation, Bulgaria, Greece, Hungary, Slovakia, Ukraine and Turkey.

These agreements contain provisions for:

- taking all appropriate and effective measures to prevent, reduce and control adverse trans-boundary environmental impacts of major nuclear activities;
- ensuring that the Parties are notified in case of nuclear accidents which could affect them.

The Romanian General Emergency Plan includes provisions for transboundary emergencies according to the provisions of national regulations.

In the licensing process, all practices needing an emergency intervention are identified by CNCAN. For practices which need emergency interventions, the Radiological Safety Report of the licensee shall include an Emergency Intervention Plan.

Basically, all licensees in Romania have to present to the regulator their emergency arrangements as part of the licensing process. Further on, requirements for the setting in operation of the Emergency Plan and for the notification of the regulator are specifically given in their license.

There is a national plan for intervention in case of nuclear accident and there are county plans for intervention for specific nuclear risk areas (emergency planning zones as per IAEA TEC DOC 953).

### ***F5.3 The implementation of emergency preparedness measures***

As national competent authority in the nuclear field, CNCAN is the national contact point as per IAEA Conventions for Early Notification and Assistance (Law no.111/1996 republished at 27/06/2006 and IAEA letter EPR/CP(0100) from 16/11/2000), with the following functions (as defined in ENATOM, 2007):

- National Warning Point;
- National Competent Authority for a Domestic Accident;
- National Competent Authority for an Accident Abroad.

CNCAN is operating its own Emergency Response Centre (ERC), as part of the National System for the Management of Emergencies. CNCAN – ERC is one of the national contact points in relation to any type of radiation emergency, including accidental events at scrap metal processing facilities and at national borders. CNCAN – ERC acts as a support centre performing technical analysis and prognosis of the emergency situations with focus on the nuclear safety, radiation protection and radiological consequences, in nuclear and radiological emergency situations.

County Emergency Plans for Radiological Accidents were elaborated in the last years, with clear specifications on notification and intervention actions for the first responders. Training and exercises were performed for the intervention personnel of some responsible organizations.

All licensees have in place Emergency Plans. The emergency Plans are developed and/or revised according to national regulations.

The notification system is established in the licensee's and public authorities Emergency Plans. Exercises and communication tests are performed between the operative centers of the National System.

There are three distinct zones in the Emergency Plans of nuclear installations: one where protective actions are implemented precautionary, one for the short term plume exposure pathway, and the other for the long term ingestion exposure pathway. The size of the zones depends on the hazard associated to the nuclear facility.

Based on the Emergency Planning Zones, the Off-site Radiation Emergency Plans describe the external organizations and their responsibilities during an accident at nuclear facilities, which may have an off-site impact. The Plans also contain a description of essential steps for off-site emergency response activation, the protective action levels, and the protective measures for the emergency personnel and population. The protective actions, and the organization in charge to implement these actions, are identified for each emergency-planning zone.

Emergency Procedures are in place, at all levels, in order to perform the response functions declared in the Emergency Plans.

## ***F6. Decommissioning (Article 26)***

### ***F6.1. General Requirements related to decommissioning***

According to the provisions of the Law no. 111/1996, the licensee shall:

- elaborate a program for preparing the decommissioning and to present it for approval to CNCAN
- pay the contribution for setting up the financial resources for decommissioning.

Based on these provisions of the law, CNCAN has issued a specific regulation on safety requirements for decommissioning of nuclear and radiological facilities, approved by the CNCAN Order No. 115/2017.

The safety and licensing requirements on decommissioning cover both nuclear and radiological facilities. The regulation is based on the IAEA recommendations provided in General Safety Requirements Part 6 Decommissioning of Facilities, as well as on the Safety Reference Levels developed by WENRA on decommissioning. The end state criteria, responsibilities of the licensees, integrated management system, safety culture, record keeping system, reporting to CNCAN are described in this regulation. The regulation defines the requirements for decommissioning strategies, planning of decommissioning activities, as well as the transition from operation to decommissioning phase and conducting of decommissioning actions. The regulation introduces the concepts of safety case and safety assessment, their contents being provided in the Annexes to the regulation. The requirements for final radiological verification are also provided. The content of the final radiological survey report as well as the final decommissioning report are provided in the Annexes to the regulation. The licensing requirements are based on the provisions of the nuclear law.

According to the above mentioned regulations the Decommissioning Plan shall be revised every 5 years.

According to the same regulations:

- for all future nuclear objectives and installations for which the regulation applies, the decommissioning plan shall be part of licence documentation, starting with the siting licence;
- for the nuclear objectives and installations for which the regulation applies that already are in the design, construction, or operation stage, the decommissioning plan (at various levels of detail, from conceptual to detailed) has to be submitted by the licence holder to CNCAN.

### ***F6.2. Fulfilment of the requirements of article 26 of Joint Convention***

All requirements of Article 26 of the Joint Convention are detailed by the CNCAN Order No. 115/2017 for approval the Regulation on the safety requirements for decommissioning of nuclear and radiological facilities.

#### ***F6.2.1. Qualified staff and adequate financial resources***

According to the CNCAN Order No. 115/2017 for approval the Regulation on the safety requirements for decommissioning of nuclear and radiological facilities, in order to get the decommissioning licence, the applicant shall prove in the decommissioning plan that qualified staff and adequate resources are available.

#### ***F6.2.2. Operational radiation protection, discharges, unplanned and uncontrolled releases***

According to the CNCAN Order No. 115/2017 for approval the Regulation on the safety requirements for decommissioning of nuclear and radiological facilities the requirements for radiation protection, discharges, and for the unplanned and uncontrolled releases during decommissioning are similar to the requirements during the operation.

For the decommissioning activity, the radiological safety requirements according to the CNCAN Order No. 14/2000 for approval the Fundamental regulation on radiological safety.

The radiation protection of persons who are exposed as a result of decommissioning shall be optimized according to the dose constraint established by CNCAN.

The licensee shall assess the radiological impact of radioactive discharges resulted from the decommissioning activity. The assessment of the radiological impact of radioactive discharges into the environment is part of the final decommissioning plan.

The licensee shall establish annual derived emission limits for radioactive liquid discharges and gaseous discharges, resulted from the decommissioning activity, ensuring the observance of the effective dose constrains established by CNCAN. The licensee shall reassess whenever necessary depending on the progress of the decommissioning activity, the impact of the radioactive discharges into the environment and the associated control measures.

The licensee shall establish and implement the programmes for monitoring of radioactive discharges and environmental radioactivity around the facility.

In the case when the end state of the facility, as it is described in final decommissioning plan, is the release from regulatory control with restriction of use of the facility or site, the licensee shall develop and implement an appropriate surveillance and monitoring programme for the period of restriction, as approved by CNCAN.

The licensee shall declare in the decommissioning plan the clearance levels used, in accordance with specific regulations issued by CNCAN. In the final decommissioning plan, the licensee shall describe all provisions to ensure that the radioactive material to be released from the regulatory control complies with the clearance levels or the derived criteria approved by CNCAN.

The licensee shall establish and implement specific arrangements for controlling the clearance of material and shall ensure their implementation during the decommissioning activity in accordance with CNCAN approval.

After the decommissioning of the nuclear or radiological facility, the end state of the site can be the unrestricted release or the release with restricted use.

### ***F6.2.3. Emergency preparedness***

According to the CNCAN Order No. 115/2017 for approval the Regulation on the safety requirements for decommissioning of nuclear and radiological facilities, an applicant for a decommissioning licence shall submit to CNCAN the emergency plan. If necessary, the General Emergency Plan and the local public authorities' plans will take into consideration the decommissioning activities.

### ***F6.2.4. Records of decommissioning operations***

According to the CNCAN Order No. 115/2017 for approval the Regulation on the safety requirements for decommissioning of nuclear and radiological facilities the licensee shall establish and implement the integrated management system and shall continuously improve it by considering the changes during the performance of decommissioning activity.

The management system shall integrate the structures, resources and the processes of the organization to fulfil the related objectives for radiological safety, health, environment, security, quality and economic matters and other considerations.

On the entire life time of the facility, the licensee shall establish, implement and archive the relevant records which need to be retrievable within reasonable timeframe.

The relevant records shall be used developing the decommissioning plan, its subsequent revisions as well as for the elaboration of the final decommissioning report. The licensee shall identify and shall include into the decommissioning plan the records on the design and design modification as well as the records on the operating history.

The licensee shall establish, implement and maintain up to date a record keeping system of the quantities, types, characteristics and management methods of the material and waste generated, stored in the facility, or transferred to another authorized facility, including those that were cleared.

### ***F6.3. Design requirements related to decommissioning***

According to the CNCAN Order No. 115/2017 for approval the Regulation on the safety requirements for decommissioning of nuclear and radiological facilities the licensee shall identify and shall include into the decommissioning plan the records on the design and design modification as well as the records on the operating history.

The licensee shall take into consideration the decommissioning in the siting, design, construction, commissioning, operation and any major modification of the facility so that to facilitate decommissioning activities, to keep the records of the facility, to limit contamination and activation and to avoid waste accumulation.

#### ***F6.4. NPP decommissioning plan***

CNE Cernavoda has elaborated and submitted to CNCAN, for approval, the following documents:

K-414716-00001 - SNN Cernavoda NPP Units 1&2 Preliminary Decommissioning Plan;

K-414716-00003 - SNN Cernavoda NPP Units 1&2 Decommissioning Costing Report.

The first mentioned document contains, at chapter 3, the “Decommissioning Strategy” and, at chapter 8, the “Cost Estimate and Funding Mechanisms”.

The structure of decommissioning plan complies both with the regulatory requirements and with the policies and plans developed by ANDR. It is also consistent with the guidance provided by international organizations, such as the International Atomic Energy Agency (IAEA), European Union (EU), Nuclear Energy Agency / Organization for Economic Co-operation and Development (OECD/NEA), the European Atomic Energy Community (EURATOM), and best industry practices reflected in the Canadian Standards Association (CSA) N294-09.

The proposed strategy for the decommissioning of CNE Cernavoda Units 1&2 consists in an optimized combination of Deferred and Immediate Dismantling. This is an alternative decommissioning strategy, as proposed by the IAEA WS-R-5 “Decommissioning of Facilities Using Radioactive Material” and current international good practice, and will be completed in five distinct phases:

1. Shutdown
2. Preparation for Safe Enclosure;
3. Safe Enclosure
4. Dismantling, Demolition and Disposal
5. Site Restoration

As stated in the CNE Cernavoda Preliminary Decommissioning Plan, demolition will be to 1m below grade (1 meter below ground level) after the structures have been cleared for free release. Remaining underground voids will be filled with crushed concrete or clean filling.

The decommissioning cost was established considering activities such as pre-decommissioning, facility shutdown, safe enclosure or entombment, dismantling, waste processing, storage and disposal, site infrastructure and operation, conventional dismantling, demolition and site restoration, fuel and nuclear material expenditures, and the asset recovery. Costing model for CNE Cernavoda Units 1&2 Decommissioning Plan was developed using the computer code OMEGA, as the universal tool for evaluation and optimization of decommissioning costs for nuclear installations, with any extent of systems and structures and with any radiological situation at the shutdown. The calculation structure is based on NEA/IAEA/EC Report No.7088 “International Structure for Decommissioning Costing of Nuclear Installations” 2012, blue book,

(ISDC), by extending the generic ISDC levels to lower levels, using several levels of ISDC templates. Executive calculation structures are generated automatically by the code based on the facility inventory database and ISDC templates.

In Romania the nuclear license holder contributes to the decommissioning funds and has to ensure that appropriate material and financial arrangements are in place for decommissioning, by the time they are needed. Government Ordinance 11/2003 stipulates the creation of the financial resources for radioactive waste management and decommissioning of the nuclear installations and establishes obligations for each radioactive waste producer to make annual contributions to those funds. The Governmental Decision no. 1080/2007 regarding the set up and management of the financial resources necessary for the safe management of radioactive waste and decommissioning of nuclear and radiological installations stipulates the creation of two separate funds: one for used fuel and radioactive waste disposal, and one for the decommissioning of the nuclear facilities.

The conceptual decommissioning plan for CNE Cernavoda Unit 1 and Unit 2 has been prepared and submitted to CNCAN. This plan has granted National Agency and for Radioactive Waste approval. This plan will be revised for compliance with the new issued CNCAN Order No.115 / 2017: Safety Regulation on decommissioning of nuclear and radiological installations.

#### ***F6.5. Status of VVR-S research reactor decommissioning***

The VVR-s research reactor is under the phase 3 of decommissioning. The revised version of the detailed decommissioning plan for phase 3 was submitted to CNCAN. According to the detailed decommissioning plan, 12<sup>th</sup> edition approved by CNCAN in 2014, the phase 3 consists of:

- Dismantling of internal active components of reactor block
- Dismantling of reactor block
- Dismantling of hot cells
- Dismantling of degasor
- Dismantling of active sewage system except 30m<sup>3</sup> tank
- Final radiological characterization
- Completion of the project.

The duration of phase 3 is foreseen for 6 years and 2 months. In 2016 was submitted and approved by CNCAN the 14th revision of the decommissioning plan.



## **SECTION G. SAFETY OF SPENT FUEL MANAGEMENT**

### ***G1. General safety requirements (Article 4)***

#### ***G1.1. Criticality and removal of heat***

In the licence process for siting, construction and operation of NPP and of research reactors, CNCAN pays special attention to:

- criticality control (not applicable for spent fuel of CNE Cernavoda);
- assurance of adequate heat removal;
- control of water parameters in wet storages, and control of confinement and of the isolation air parameters for dry storage, in order to ensure optimum storage conditions (control of corrosion) and control of radioactivity levels.

#### ***G1.2. Minimization of waste***

Generation of radioactive waste associated with spent fuel management is minimized through

- the quality of fuel
- online fuelling (this allows through the systems for detecting the failed fuel and immediate replacement)
- canning of the failed fuel
- the control of water parameters for wet storages
- control of confinement and of the isolation air parameters for dry storage.

#### ***G1.3. Interdependencies among different management steps***

The Romanian strategy for spent fuel management takes into consideration both the present and future storage capabilities, and the actual status of the fuel cladding. In the licensing of the new NPP dry storage for spent fuel, the relations between the intermediate storage stage and the following stage, when the fuel will be removed for transfer in the geological repository, were taken into consideration.

#### ***G1.4. Effective protection of individuals, society and environment***

In the licensing process, CNCAN pays due attention to the effective protection of workers, public and environment. The licence is granted only if the internationally recognized criteria and standards are observed.

In order to protect adequately the public health and the environment during the normal operation of the spent fuel management facility, the dose estimate and monitoring are based on the analysis of the external effective doses and of the (internal) committed effective doses for members of critical groups for all radiation pathways. These analyses are performed according to methods and procedures recommended in IAEA and in other western regulations. The result of the analyses leads to derived emission limits for the effluents, and the monitoring program of the environment shall demonstrate that the derived emission limits are observed both in normal operation and during events with relative high probability of occurrence.

Regarding the assumed accident scenario and the scope of the emergency plan it shall be mentioned that the Initial Nuclear Safety Analysis Report, the Preliminary Nuclear Safety

Analysis Report, and the Final Safety Analysis Report for a spent fuel management facility have chapters regarding the assessment of natural effects (e.g. earthquakes, natural fire, flooding, snow) and of the manmade effects (e.g. explosions, air plane crashes).

The above documents include accident analyses, according to the CNCAN requirements. For the Design Basis Accidents, the doses shall remain below specified values, while, in order to prepare the emergency plan, Beyond Design Basis Accidents are analyzed. For example CNCAN asked that the Preliminary Safety Analysis Report for the construction licence of the Spent Fuel Dry Storage of CNE Cernavoda addresses an air plane crash on the storage and this requirement was implemented.

### ***G1.5. Biological, chemical and other hazards***

The criteria and standards mentioned in paragraph G1.4 take into consideration biological, chemical and other hazards that may be associated with spent fuel management.

### ***G1.6. Impact on future generations***

The licensing process for transport and storage of spent fuel, and, when it will be the case, for its geological disposal requires the demonstration that the impact on future generations will not be higher than it is now accepted for the current generation.

### ***G1.7. Avoidance of undue burdens on future generations***

Regarding the principle of avoiding undue burdens of spent fuel management on the future generations, it shall be noted that Romanian authorities, fully accept and promote this principle. In this respect, based on the provisions of Governmental Ordinance no.11/2003 were created the Funds earmarked for management of radioactive waste and for decommissioning of nuclear installations.

## ***G2. Existing facilities (Article 5)***

### ***G2.1. Review of the safety of the spent fuel management facilities of CNE Cernavoda***

The general safety requirements implemented in design, construction and operation of the CNE Cernavoda are applicable for the fuel handling system, including spent fuel bay and dry storage facility. The safety assessment reports prepared for nuclear licensing of the CNE Cernavoda include specific safety assessment for the spent fuel management.

During the licensing process, CNCAN paid a special attention to evaluation of the following safety and safety related functions:

- removal of the residual heat;
- control of water chemical and physical parameters, in order to ensure optimum storage conditions and radiation levels control.

The spent fuel management facilities of CNE Cernavoda were designed to meet adequate safety standards used in Canada and in other five countries.

Design of the spent fuel management facilities at CNE Cernavoda meets the general requirements as described in the IAEA Safety Series 116 – Design of spent fuel storage facilities by including the following:

- measures to limit radioactive releases and radioactive exposures of workers and the public (including detection of leakage through the bay walls and floor);
- measures to prevent anticipated operational occurrences and accident conditions from developing into unacceptable severe accident conditions;
- provision for ease of operation and maintenance of essential equipment;
- provision through equipment and procedures for retrieving spent fuel from storage.

After minimum 6 years storage in the spent fuel bay, the spent nuclear fuel from operation of CNE Cernavoda is transferred to the Intermediate Dry Storage Spent Fuel Facility (DICA) that has a designed lifetime of 50 years.

The spent fuel management facilities of CNE Cernavoda have been subject to a systematic safety review, in accordance with the technical specification defined by ENSREG as part of the EU NPPs Stress test. The results of the evaluation show the facilities as being robust, with a significant safety margin for all the initiating events considered as part of the evaluation (earthquakes, external flooding and severe weather events). Consequently no changes on the design basis have been identified as being required.

However, in order to increase the CNE Cernavoda response during beyond design bases events, design improvements have been made to Spent Fuel Bay, such as:

- water level and temperature monitoring from outside the Spent Fuel Bay (SFB) building, to facilitate operator actions in preventing a severe accident in SFB;
- a seismic qualified line to Spent Fuel Bay has been installed, to ensure cooling under severe accident conditions, and
- provisions have been assured for vapours natural ventilation of and steam evacuation.

### ***G2.2. Spent Fuel Bay and dry storage of spent fuel elements and fragments at ICN Pitesti***

The general safety requirements implemented in design, construction and operation of the TRIGA reactor are also applicable for the spent fuel storage.

There are several safety criteria that have to be fulfilled by the spent fuel storage system:

- criticality control (storage geometry designed such as  $k_{\text{eff}} < 0.8$ )
- residual heat removal: natural convection allowed such as fuel temperature not to exceed 200°C;

Additional storage requirements for safe storage are:

- Water chemistry: same chemical and physical parameters as in the bulk of the reactor pool.
- Water level above the top of the rack for (~5m) for radiation protection.
- Water radionuclide purity: periodic sampling for gamma ray spectrometry analysis to detect occurrence of leaks from stored spent fuel.

As a general rule for spent fuel management, the first storage location after fuel bundle removal from the reactor core is a temporary storage in the reactor pool. After 1 year of cooling down in this rack the fuel bundles are transferred to the previously described storage rack for 20-30 years.

For the time being no spent fuel is stored in any of the racks.

In the dry storage pits of the Post Irradiation and Examination Laboratory there are CANDU type irradiated fuel rods as well as fragments resulted from destructive testing of these rods. The Hot Cells handling capacity is 1MCi  $^{60}\text{Co}$  (equivalent).

### ***G3. Siting of proposed facilities (Article 6)***

#### ***G3.1. Procedures for safety evaluation, public information and neighbour countries consultancy***

##### ***G3.1.1. Site related factors likely to affect the safety of the facility***

As mentioned before, any proposed facility needs a siting licence issued by CNCAN based on Law no. 111/1996. The siting process for Cernavoda Interim Spent Fuel Dry Storage Facility was implemented based on IAEA guidance and NRC – 10 CFR Part 72.

The following issues were addressed in the Initial Safety Analysis Report submitted to CNCAN for siting licence:

- General description
- Characteristics of the site (these includes: geography and demography, nearby human activities, including man made events, meteorology, hydrology, hydrogeology, geology, seismology, ecology, use of land and waters)
- Design criteria
- Description of the project
- Description of the functioning of the installation
- Waste management
- Radiological and nuclear safety
- Accident analyses
- Decommissioning
- Conclusions.

The Initial Safety Analysis Report and its supporting documents are evaluating all the relevant site factors likely to affect the safety of the Spent Fuel Dry Storage Facility and the likely safety impact of the facility on individuals, society and environment, as presented in the paragraph on article 4.

The siting licence was issued by CNCAN in August 2001, and contains the conditions related to the constructive solution, the confirmation of seismic entry data, and the completeness of list of Design Basis Accidents. It was also required for the Preliminary Safety Analysis Report, requested in support of the application for construction licence, to demonstrate the observance of dose constraint for the members of the public during normal operation (0.1 mSv/year) and to demonstrate the observance of Romanian regulations related to dose limits in case of Design Basis Accidents (the exclusion zone and the reduced population zone shall remain inside the area established for CNE Cernavoda site). It was also required that the Preliminary Safety Analysis Report present also the doses for Beyond Design Basis Accident.

For future siting of reactors, if it will be the case, the siting licence process will cover in a similar manner the spent fuel management, as the requirements for NPPs or research reactors siting are covering the field of spent fuel handling and storage.

The spent fuel management facilities of CNE Cernavoda have been subject to a systematic safety review, in accordance with the technical specification defined by ENSREG as part of the EU NPPs Stress test. The results of the evaluation show the facilities as being robust, with a significant safety margin for all the initiating events considered as part of the evaluation (earthquakes, external flooding and severe weather events). Consequently no changes on the design basis have been identified as being required.

### ***G3.1.2. Safety impact of the facility on individuals, society and environment***

The chapter on accident analyses of the Initial Safety Analysis Report addresses the safety impact of the facility on individuals, society and environment, in case of accident. For normal operation, the safety impact is assessed in the chapter on radiological and nuclear safety.

### ***G3.1.3. Public consultation***

When selecting a site, the future licensee has to consult the public. The Environment Agreement is issued by the Environmental Protection Authority, after analyzing of the Environmental Impact Study. Public consultancy of this study is required, and the decision for issuing the Environmental Agreement takes into account the opinion of the members of the public. The Environmental Agreement is a prerequisite for issuing by CNCAN of the siting licence.

The above mentioned consultancy process is done based on the transposition of the Directive 85/337/EEC on Environmental Impact Assessment, amended by the Directive 97/11/EC. The transposition is realized through the Emergency Governmental Ordinance no. 195/2005 on Environmental Protection, modified and approved by the Law no. 265/2006 and the Orders of the Minister of Waters and Environment Protection no. 860/2002, no. 863/2002 and no. 864/2002.

### ***G3.1.4. Consultation of Contracting Parties in the vicinity of the spent fuel management facilities***

Romania has ratified the ESPOO Convention. Consequently, any country (not only a Contracting Part), that could be affected by a spent fuel management facility sited on Romanian territory will be announced, and will receive, upon request, the general data relating to the facility to enable it to evaluate the likely safety impact of that facility upon its territory.

Aarhus Convention on access to information, public participation in decision-making and access to justice in environmental issues, which has been ratified by Romania through the Law 86/2006, is also taken into account in the public consultation process.

### ***G3.2. Avoidance of unacceptable effects on Contracting Parties in the vicinity of the spent fuel management facilities***

The Initial Safety Analysis Report, as well as the latter Preliminary Safety Analysis Report and Final Safety Analysis Report, for any new nuclear facility (not only for spent fuel management facilities) shall prove that the national requirements, which are in line with the internationally

endorsed criteria and standards, are met for individuals, society and environment, at the same level for national territory and for neighbor countries.

This requirement is obviously fulfilled for fuel handling and storage facilities. When siting a spent fuel deep geological repository, due consideration will be given to the assessment of the impact on neighbor countries.

#### ***G4. Design and construction of facilities (Article 7)***

##### ***G4.1. Construction of Spent Fuel Handling and Storage Systems at CNE Cernavoda Unit 2***

The design and construction of the spent fuel handling and storage facilities at NPPs and research reactors are part of the design and construction of the plants, respectively of the reactors. As all of the requirements of Article 7 of the Joint Convention are required by the Romanian legislation for all nuclear installations (for all the installations, not only for spent fuel management systems), the construction licence of a NPP or research reactor is granted by CNCAN only if, inter alia:

- i.* the design and construction of the spent fuel handling and storage system provide for suitable measures to limit possible radiological impacts on individuals, society and environment;
- ii.* at the design stage, conceptual plans and, if necessary, technical provisions for the decommissioning of spent fuel management facility are taken into account;
- iii.* the technologies incorporated in the design and construction of spent fuel management facility are supported by experience, testing or analysis.

As it was presented in the paragraph on article 6, the spent fuel system of CNE Cernavoda Units 1 and 2 were designed to meet adequate safety standards used in Canada.

The Spent Fuel Bay of CNE Cernavoda – Unit 2 design meets the general requirements as described in the IAEA Safety Series 116 – Design of spent fuel storage facilities by including the following:

- measures to limit radioactive releases and radioactive exposures of workers and the public (including detection of leakage through the bay walls and floor);
- measures to prevent anticipated operational occurrences and accident conditions from developing into unacceptable severe accident conditions;
- provision for ease of operation and maintenance of essential equipment;
- provision through equipment and procedures for retrieving spent fuel from storage.

It should be mentioned that, prior the restarting of the construction of Unit 2, a review of the nuclear safety of the unit under construction was performed through a PHARE project. In one of the ten tasks of this project, entitled Task - 6 Evaluation of Adequacy of Engineered Provisions for Radiation Protection, it is recommended to review the suitability and application of the spent fuel pool surface finish and to consider the installation of a suitable metallic liner, to fulfill the secondary containment requirement. This design change was applied for the construction of Unit 2.

##### ***G4.2. Construction of Cernavoda Interim Spent Fuel Dry Storage Facility (including handling systems)***

- i.* The design of Cernavoda Interim Spent Fuel Dry Storage Facility provides measures to limit the possible radiological impact on people and environment:

- double confinement barriers
- massive reinforced concrete construction
- low temperature on spent fuel cladding

*ii.* Decommissioning is adequately addressed by the Preliminary Safety Analysis Report.

*iii.* The Cernavoda Interim Spent Fuel Dry Storage facility uses a well-proven technology that is in use since the mid 70's.

The design of the Cernavoda facility specifically uses the best features of two operating dry storage facilities at Point Lepreau and Gentilly 2 in Canada. The dry storage system has proved to be safe, simple to use, and has successfully limited doses of radiation to workers to very low values at each of the above facilities.

The content of the Preliminary Safety Analysis Report is presented below:

- General description
- Characteristics of the site (these includes: geography and demography, nearby human activities - including manmade events, meteorology, hydrology, hydrogeology, geology, seismology, ecology, use of land and waters)
- Design criteria
- Description of the project
- Description of the technological flux
- Waste management
- Radiological protection
- Conduct of operation
- Accident analyses
- Technical limits and conditions
- Quality Assurance
- Decommissioning program
- Conclusions

The Physical Protection and Safeguards are addressed separately. Emergency Planning is covered by the general NPP emergency plan that integrates emergencies related to dry storage activities.

The construction of the first module of the facility was done under 2 different licences issued by CNCAN.

First licence was given in the form of a "Modification of Plant Approval" for Unit 1, in the area of the Spent Fuel Storage Bay, including the construction of an extension of the building. The modifications related to this area were approved only after demonstration that construction works will not affect the safety of the operation of the plant.

The construction licence of the first module of spent fuel dry storage was issued in May 2002, and contains conditions related to the constructive solution, and to the reconsideration of the air crash severe accident (it is requested that the Final Safety Analysis Report improve the scenario, justify the emission height, and presenting the support documentation for radionuclide concentrations and dose calculations, for all meteorological conditions and all distances and heights relevant for emergency planning).

Also it was requested to be analysed the situation of a critical group inside the exclusion zone, and to demonstrate that in normal operation, the dose constraint for members of the public is not

exceeded, and, in case of Design Basis Accidents, the doses for public will in principle not exceed the dose limits applicable for workers during normal operation).

All these requirements have been addressed in the Final Safety Analysis Report that was submitted to CNCAN in order to obtain the operating license of module 1 of the Spent Fuel Dry Storage Facility.

In 2017, 8 modules are licensed for operation, based on the revised Final Safety Analysis Report.

The spent fuel management facilities of CNE Cernavoda have been subject to a systematic safety review, in accordance with the technical specification defined by ENSREG as part of the EU NPPs Stress test. The results of the evaluation show the facilities as being robust, with a significant safety margin for all the initiating events considered as part of the evaluation (earthquakes, external flooding and severe weather events). Consequently no changes on the design basis have been identified as being required.

## ***G5. Assessment of safety of facility (Article 8)***

### ***G5.1. Initial safety assessment***

According to the Romanian laws and regulations, for siting a nuclear facility, including a spent fuel management facility, a siting licence shall be issued by CNCAN. This licence is issued based on an Initial Safety Analysis Report, as it was presented in the paragraph related to article 6.

As it was presented in the paragraphs related to articles 6 and 7, before construction of any nuclear facility, including a spent fuel handling and storage facility, an environmental agreement issued by the Environmental Protection Authority and a construction licence issued by CNCAN are required. The environmental agreement is issued based on an Environmental Impact Study while the CNCAN safety licence is issued on the basis of a Preliminary Safety Analysis Report.

### ***G5.2. Updated and detailed safety assessment***

According to the Romanian laws and regulations, for issuing by CNCAN of a commissioning licence for a nuclear facility, including a spent fuel handling and storage facility, a Final Safety Analysis Report is required. The amended Final Safety Analysis Report is then necessary for trial operation licence and for the operation licence.

Operation requires also the issuing by the Environmental Protection Authority of an operating licence. This licence is issued after starting of the operation, based on the Environmental Report that includes measurements of environmental parameters.

The operating licences are issued by CNCAN and by the Environmental Protection Authority for a limited period of time and have to be renewed periodically. That requires the update of supporting safety and environmental assessments.

Systematic impact assessment according to internationally recognized criteria and standards are required for completion of the Environmental Impact Study and of the Environmental Report.

The Initial Safety Analysis Report, Preliminary Safety Analysis Report, Final Safety Analysis Report and their supporting documents are containing systematic assessments of the nuclear safety and of the environmental impact, in accordance with the internationally accepted criteria



and standards. This is obviously the case for the spent fuel facilities inside the NPP or reactors, where the safety of the handling and storage of spent fuel are assessed in the general context of the safety of the entire installation.

CNCAN has and will continue to assess the licensing documents based on USNRC NUREG-1567 “Standard Review Plan for Spent Fuel Dry Storage Facilities”, adapted taking into account the characteristics of CANDU spent fuel, the local geographic and climatic conditions and the regulatory requirements. This approach was communicated to the utility from the beginning of the licensing process.

The handling of spent fuel in TRIGA pool, at ICN Pitesti, is covered in the Final Safety Analysis Report of TRIGA reactor. The revised Final Safety Analysis Report of LEPI covers the storage of the spent fuel in the spent fuel storage pool of LEPI and of the spent fuel fragments and experimental fuel elements in the dry pits of LEPI hot cells. The report covers handling and storage of spent fuel in LEPI, according to the requirements of IAEA SS No. 118.

## ***G6. Operation of facilities (Article 9)***

### ***G6.1. Licensing***

The spent fuel bays operated by CNE Cernavoda Unit 1 and Unit 2 are nuclear power plant systems. The CNE Cernavoda operation was licensed by CNCAN following the legal procedure and based on appropriate assessment of safety. All safety analyses to support the five-formal licensing stages (site licence, construction licence, commissioning licence, trial operation licence and operation licence) were performed as parts of the safety analyses for Unit 1 and Unit 2.

The trial operation licence was issued based on the amended Final Safety Analysis Report, which includes the commissioning test and control program results. The operation licence was issued based on the amended Final Safety Analysis Report (phase II). The amended report contains information derived from the results and conclusions of the trial operating period.

The operation licence is renewed periodically. In 2014 was issued the operation licence for the Spent Fuel Dry Storage with 6 modules.

Similar processes were in place for licensing of operation of the Triga research reactor. Also the operating licence of LEPI was issued in similar conditions.

### ***G6.2. Operational limits and conditions***

For the new Cernavoda Spent Fuel Dry Storage Facility, a set of technical limits and conditions were proposed in the Preliminary Safety Analysis Report, and were finalized in the Final Safety Analysis Report and approved by CNCAN by issuing the operating licence for the first module in the year 2003, the second module in 2006 and third module in 2008, the fourth module in 2010, the fifth module in 2012, the sixth module in 2014, the seventh in 2015 and the eighth module in 2017. These limits and conditions are equivalent with the reference document “Operating Polices and Principles” that is used for CNE Cernavoda units.

For TRIGA reactor and LEPI Pitesti facilities, technical (operational) limits and conditions are established, based on assessments, tests and operational experience. These technical limits and conditions are revised as necessary.

### ***G6.3. Operation, maintenance, monitoring, inspection and testing***

As parts of CNE Cernavoda, the spent fuel facilities operation, maintenance, monitoring, inspection and testing activities are performed according to Station regulations: Operating Policies and Principles, Maintenance Philosophy, Quality Management Manual.

All these documents include, directly or by reference to appropriate procedures, rules that must be followed in performing activities related to operation, maintenance, monitoring, inspection and testing.

As these documents are sustaining the operating licence, the compliance with their requirements is mandatory for the Station and any deviation must be reported to CNCAN.

Similar requirements do exist for TRIGA reactor and for LEPI.

### ***G6.4. Engineering and technical support***

The station organization chart for CNE Cernavoda documents the general areas of responsibility. The structure of the organization considers the needs for engineering and technical supports and for this reason it includes a strong Technical Unit covering System Performance Monitoring, Design Engineering and Component Engineering.

Also, it should be mentioned that a strong link is maintained with Romanian research institutes and with designer of the plant, SNC Lavalin – Candu Energy Inc. (former Atomic Energy of Canada Limited), Romania being member of CANDU Owners Group.

ICN Pitesti and IFIN-HH consider also needs for engineering and technical supports. Their organizational chart includes also staff for operation, maintenance, monitoring, inspection and testing of spent fuel handling and storage systems.

### ***G6.5. Incidents reporting to CNCAN***

Incidents significant to safety are reported in a timely manner by the CNE Cernavoda to CNCAN, according to established procedures. These reports and procedures are requested by CNCAN according to licensing conditions.

Abnormal Condition Reports are prepared to report those events that could have significant adverse impact on the safety of the environment, the public or the personnel, such as: serious process failures, violations of the Operating Policies and Principles, release of radioactive materials in excess of targets, doses of radiation which exceed the regulatory limits, events which interfere with the IAEA safeguards system. For each reportable event a notification is made to CNCAN immediately after the discovery of the reportable event or within one working day depending on the gravity of the event a report is prepared to document the event. For the events that are significant or complex, more detailed reports are prepared as Abnormal Condition Reports and submitted to CNCAN within the required time period.

Similar reporting systems are established in the licensing conditions and are mentioned in internal procedures of the licensee, in the case of ICN Pitesti and of IFIN-HH.

### ***G6.6. Collection and analysing of relevant operating experience***

For CNE Cernavoda the station goal for operating experience is to effectively and efficiently use lessons learned from other plants and station operating experience to improve plant safety and reliability.

Station events and human performance problems often result from weaknesses or breakdowns in station processes, practices, procedures, training and system or component design that were not previously identified or corrected. This is the reason why CNE Cernavoda considers, as the main topic of the Operating Experience Program, the Event Analysis System, comprising identification, evaluation and analysis of operational events (both internal and external) in order to establish and implement corrective actions to avoid re-occurrence.

The external information regarding operating experience proved to be a very important tool in improving station performance. Therefore, the second main topic of the operating experience program is the Information Exchange Program, with bi-directional use:

- collecting of external information and distribution to the appropriate station personnel;
- submitting the internal operating experience information to external organizations.

The basis for Operating Experience Program was set in place since the early stage of the commissioning phase, with the objective to ensure:

- the reporting, reviewing, assessing of the station abnormal conditions and establishing of the necessary corrective actions;
- information exchange within WANO and CANDU Owner Group (COG), regarding abnormal conditions, technical problems, research and development projects, etc.

For the information exchange program, the relation between CNE Cernavoda and COG is covered by a COG contact officer, appointed by the station management, with the following general responsibilities:

- serving as a liaison between COG and the station;
- reviewing the incoming messages and distributing them to the appropriate persons;
- ensuring the transmittal of the required information/reports to COG;
- ensuring optimum participation by the station personnel.

Programs to collect and analyze relevant operating experiences are established also for ICN Pitesti and IFIN-HH.

#### ***G6.7. Decommissioning plans for spent fuel management facilities***

According to the provisions of Law no. 111/1996 any nuclear or radiological facility needs to prepare a decommissioning plan. This is valid also for the spent fuel management facilities that in Romania are sited at reactor sites. The requirements related to decommissioning programs from the design and construction phases are applied for the Spent Fuel Dry Storage Facility at Cernavoda site, as presented before.

#### ***G7. Disposal of spent fuel (Article 10)***

For planning purposes, an indicative timeline with key milestone dates has been set out for the geological repository implementation programme. This anticipates that an underground research laboratory (URL) will be constructed at the chosen site to confirm the suitability of the underground conditions. The repository will then become operational in around 2065 and there will be parallel phases of construction and operation until the repository is closed in around 2150.

An earlier countrywide assessment of geological environments identified 6 potentially suitable rock types including granite, green schists, basalt, clay, salt and volcanic tuffs. No decision on a preferred host rock and geological environment has been made, and a future site characterization and selection process will be established.

## **SECTION H. SAFETY OF RADIOACTIVE WASTE MANAGEMENT**

### ***H1. General safety requirements (Article 11)***

#### ***H1.1. Control of criticality and heat generation***

The requirements regarding the control of criticality and heat generation during radioactive waste management are generally related, in Romanian case, to the spent fuel management. The CNCAN requirements and the measures taken by the licensees were presented in Section G.

Regarding the sealed sources of high activity, the storage licensing requirements take into consideration heat dissipation. When the sources are stored in the dedicated transport, storage or operation container, the conditions related to heat removal are mentioned also in the type approval of the equipment.

#### ***H1.2. Minimization of waste***

Waste minimization is considered by the CNCAN Order No. 56/2004 for approval the Fundamental regulation on the safe management of radioactive waste. According to this regulation, the generation of radioactive waste is to be kept to the minimum practicable level in terms of activity and volume through appropriate design measures, facility operation and decommissioning practices. In order to meet this requirement, the operator must ensure: a) selection and control of materials; b) recycling and reuse of materials, including clearance of materials; c) implementing adequate operating procedures, including those referring to the physical, chemical and radiological characterization of the waste and sorting of different type of materials.

The operators of the main nuclear and radiological installations have started to develop characterization programme of the waste before clearance which should decrease the volume of radioactive waste generated.

#### ***H1.3. Interdependencies among different management steps***

In the regulatory process, CNCAN requires that due attention be given to interdependencies among the different steps in radioactive waste management.

According to the CNCAN Order no.56/2004 for approval of Fundamental regulations on safe management of radioactive waste and spent nuclear fuel, the interdependencies among all steps in radioactive waste generation shall be appropriately taken into account. The fulfillment of this condition shall be reviewed by CNCAN during the licensing process of radioactive waste management activities. Also, while assessing the regulatory compliance of the national radioactive waste management strategy elaborated by ANDR, CNCAN shall verify if the interdependencies among different radioactive waste management strategy were correctly taken into consideration.

#### ***H1.4. Effective protection of workers, public and environment***

In the licensing process of radioactive waste management facilities, CNCAN pays due attention to the effective protection of workers, public and environment. The licence is granted only if the national criteria and requirements on the radiological safety are observed.

In order to protect adequately the public health and the environment during the normal operation of the facility, the off-site dose estimate and monitoring are based on the analysis of the external effective doses and of the (internal) committed effective doses for members of critical groups for all radiation pathways. These analyses are performed according to methods and procedures recommended in IAEA safety standards and in other western regulations. The result of the analyses leads to derived emission limits for the effluents, and the monitoring program of the environment shall demonstrate that the derived emission limits are observed both in normal operation and during events with relative high probability of occurrence. Of a particular interest is the assessment and the monitoring of the doses resulted from a repository during both the operation and the post closure period. For this purpose, depending on the characteristics of the radioactive waste, the immobilization matrix, the engineered barriers of the facility and of the surroundings of the facility (near field and far field), various monitoring activities for radioactivity of air, water, soil, vegetal and animal organisms are performed. For a surface repository, accepting short lived radionuclides, the institutional control period is established in the licence.

The radiation protection criteria for the workers and for the public, are mentioned in the CNCAN Order no.14/2000 for approval the Fundamental Regulation on Radiological Safety.

In the case of the radioactive waste disposal facility, altered evolution scenarios, including the intrusion scenarios are considered, according to IAEA recommendations. Also operation and transport accidents are considered for such facilities. The loss and the theft of radioactive waste are also considered. The emergency plan is dimensioned according to the maximum credible accident.

For the low level radioactive waste treatment plants and for the low and intermediate level radioactive waste and spent sources storages the operation and transport accident scenarios, including loose and the theft of radioactive waste, are also considered.

#### ***H1.5. Biological, chemical and other hazards***

The internationally accepted criteria and standards used for assessing and licensing the radioactive waste management facilities take into consideration biological, chemical hazards.

#### ***H1.6. Impact on future generations***

The licence process for pre-treatment, treatment, storage and disposal of radioactive waste, requires the demonstration that the impact on future generations will not be higher than it is now accepted for the current generation. This is done for long term storage and disposal by requiring that the dose to be assessed both for normal and altered scenarios of evolution of the facility, including the intrusion in the repository, for all the period of time for which the waste has significant radioactivity. The results shall be below the constraints established by CNCAN that are expressed in terms of yearly dose or dose/event, which are the same as for the current generation.

#### ***H1.7. Avoidance of undue burdens on future generations***

Regarding the principle of avoiding undue burden of radioactive waste management on the future generations, it shall be noted that Romanian authorities, and particularly CNCAN, fully accept and promote this principle. The Governmental Ordinance no.11/2003 with subsequent modifications and completions requires that the producers of radioactive waste pay financial contributions to the Fund earmarked for management of radioactive waste and to the Fund for decommissioning of nuclear installations.

The CNCAN Order No. 56/2004 for approval the Fundamental regulations on safe management of radioactive waste and spent nuclear fuel requires the radioactive waste to be managed in such a way that will not impose undue burdens on future generations. The radioactive waste management strategy to be revised by ANDR shall observe this principle.

## ***H2. Existing facilities and past practices (Article 12)***

### ***H2.1. Safety of radioactive waste management***

#### ***a) CNE Cernavoda***

The review of the safety of radioactive waste management systems at CNE Cernavoda is done periodically, as per licence provisions.

The generation of radioactive waste resulting from plant operation is kept to the minimum practicable. Station references documents and procedures are focused on waste minimization. Radiation exposure of the operating staff and members of public during processing and storage is maintained as low as reasonably achievable – ALARA (social and economic factors taken into account).

The contamination control, temporary accumulation and storage of radioactive waste within the plant are avoided by proper planning and scheduling. Temporary accumulations are prohibited except at locations designed for that purpose.

The procedures dealing with waste generation and waste management are under regulatory control.

Qualified and trained personnel operate facilities. Training is subject to periodical refreshment.

The plant has the capabilities to control, collect, handle, process, interim store wastes that may contain radioactive materials and are produced as a consequence of plant operation.

The design of the radioactive waste management facilities is such that radiological exposure of operating staff and the public is well within the limits established by CNCAN.

The solid radioactive waste which results from either normal or abnormal operation of the nuclear power plant is stored for a limited period of time. The waste will be transferred for disposal at the moment when the disposal facility will be available.

The radioactive waste management facilities are located within CNE Cernavoda exclusion zone and security fence, with easy access of vehicles transporting radioactive wastes, minimizing the need for additional security mechanism to assure its integrity.

The description of radioactive waste management at CNE Cernavoda is presented in section D.

The conclusions of the review of the safety of radioactive waste management at CNE Cernavoda are that, in general, the requirements of the Joint Convention are met. However, CNCAN asked for supplementary work, in order to characterize in detail the radioactive waste produced in the plant. This requirement is important, as CNE Cernavoda shall select the treatment and conditioning technologies according to the near surface disposal concept of radioactive waste.

*b) FCN Pitesti*

The review of the safety of radioactive waste management at Nuclear Fuel Plant (FCN Pitesti) is done periodically, as the authorization of the facility is renewed. The description of radioactive waste management at FCN Pitesti is done in Section B.

The conclusions of the review of the safety of radioactive waste management at FCN Pitesti are that this is done properly, in accordance with the requirements of the Joint Convention.

In the Safety Analyzing Report (RAS) requested by CNCAN there are details in the chapter Waste Management. RAS is revised periodically.

*c) ICN Pitesti*

The review of the safety of radioactive waste management facilities at ICN Pitesti is done periodically, as the licence of this facilities is renewed.

STDR Pitesti is provided with installations for safe management of all short lived radioactive waste arising from the operation of the ICN Pitesti facilities. LEPI facility is used for storage of long-lived radioactive waste and of the highly active short lived radioactive sources.

The generation of radioactive waste resulting from STDR and LEPI operation is kept to the minimum practicable.

Radiation exposure of the operating staff and members of public during processing and storage of radioactive waste is maintained as low as reasonably achievable – ALARA (social and economic factors taken into account).

The contamination control is permanently maintained, temporary accumulation and storage of radioactive waste within the STDR are avoided by proper planning and scheduling. Temporary accumulations are prohibited except at locations designed for that purpose. The conditioned solid radioactive wastes are transferred to IFIN-HH for disposal at Baita-Bihor repository.

The procedures dealing with management of radioactive waste are under regulatory control.

Qualified and trained personnel operate facilities. Training is subject to periodically refreshment.

The design of the radioactive waste management facilities is such that radiological exposure of operating staff and the public is well within the limits established by CNCAN.

The conclusions of the review of the safety of radioactive waste management at ICN Pitesti are that activities are performed properly, in accordance with the requirements of the Joint Convention.

*d) IFIN-HH*

The review of the safety of radioactive waste management at STDR Magurele is done periodically, as the licence of this facility is renewed.



STDR Magurele is provided with installations for safe management of all short lived radioactive waste arising from the operation of the IFIN-HH facilities, including the former VVR-S reactor, under decommissioning, as well as of the non fuel cycle radioactive waste produced all over the country. The radioactive wastes, including spent sources, are treated at STDR. Here are stored also long lived radioactive spent sealed sources. There is a facility reconditioning of Ra-226 sources, in accordance with IAEA recommendations.

Under the Programme for decommissioning of the VVR-S research reactor, modernization of the waste processing facilities and repatriation of the spent fuel, started in 2010 were finalized.

The DNDR Baita-Bihor (the short lived radioactive waste national repository for non fuel cycle waste) was put in operation in 1985. Following the evolution of radioactive waste disposal concept, CNCAN has asked and IFIN-HH performed an Initial Safety Analysis Report, followed by a Preliminary Safety Analysis Report, and a Final Safety Analysis Report.

*e) CNU*

In accordance with the regulations issued by CNCAN the CNU Feldioara subsidiary has decided new safety measures for the radioactive waste management:

- the entire area around both new and old radioactive waste storage surfaces were surrounded by wire fence to avoid people's access;
- the surrounding area is radiological monitored and ground and underground water samples are taken and analyzed within the plant laboratory;
- to avoid radionuclides migration around the storage area the stored radioactive waste is compacted and covered by a 10 cm thick layer of clay (according to the procedures "Location and storage of low level radioactive waste" and "Conditioning of radioactive waste material easily removed by wind").

Having as aim the increasing of radioactive waste safety management, for the near future the CNU Feldioara subsidiary foreseen the following:

- improvement of the access road at the radioactive waste storage facility;
- supplementary drillings around the radioactive waste storage facility in order to ensure more underground water samples for contamination assessment;
- radiometric monitoring of the access road to the radioactive waste facility.

Remote access will be ensured to the storage area.

After filling completely the radioactive waste storage facility, the stored material will be equalized and covered by a 50 cm thick compacted clay to avoid any radioactive contamination of the surrounding environment (according to the procedure "Insulating the area of the full capacity storage facility"). In this way, the storage will be transformed in a repository.

If required, a higher storage capacity may be developed in future, within the same area, after obtaining the necessary CNCAN licence. For the first two solid radioactive waste storage areas that are closed and covered, it is also necessary to assess the safety prior to get the licence for transforming the storage areas in repositories.

## ***H2.2. Past practices***

*a) Sterile rock and low radioactive rock dumps resulted from geological research and mining activities for uranium ores production within the CNU sites*

The uranium geological research and mining activities have produced sterile rock and radioactive rock dumps. They are seven main deposits which shall be assessed, and where necessary, intervention shall be applied, in order to reduce the radiological risks. These sites were presented within the 5<sup>th</sup> JC report.

Within the Banat county former uranium mines, mine waters are pumped from underground works at a flow rate of 1,500 m<sup>3</sup> /day and are treated within a plant where the uranium is removed to a residual concentration of 0.1 mgU/l. Currently, decommissioning and environmental remediation works are ongoing.

*b) Sterile rock and low radioactive rock dumps resulted from geological research and mining activities for uranium ores production within the S.C. Radioactive Mineral Magurele Company sites*

The objectives are former geological sites searched by drilling and underground mining works during 1952 – 2002 period. All works are closed in present and proposed for final remediation. A number of 15 sites were radiological assessed during the last years in order to plan future environmental remediation works, funded by S.C. Conversmin S.A.

**H3. Siting of proposed facilities (Article 13)**

**H3.1. Procedures for safety evaluation, public information and neighbour countries consultancy**

**H3.1.1. Site related factors likely to affect the safety of the facility**

The implementation of the Romanian national strategy for radioactive waste management aims to create an operating repository for low- and intermediate-level radioactive waste by 2023. The facility will be suitable to accommodate short-lived radioactive waste, with long-lived radionuclides in limited quantities originating from operation and decommissioning of four units at CNE Cernavoda assuming 30 to 40 years of operational lifetime per unit. The concept proposed for disposal of the waste is a near-surface repository with multiple barrier system. The repository is composed of disposal cells located on the ground surface. The cells are placed on a foundation, built on an improved foundation soil. Into the disposal cells are located the disposal modules, which contain waste packed in drums, conditioned and stabilized by cementation into a disposal matrix. After the introduction of the disposal modules into the cell, the empty spaces are filled with sand. Above the last level of the disposal modules there is another layer of backfilling material up to the reinforced concrete plate. The general view of the repository structure is presented in Figure H1.

The siting process for a near-surface repository for low and intermediate-level radioactive waste was initiated in Romania by the SNN in 1992. The Dobrogea region was selected in a regional mapping stage and the site selection process then identified 37 potentially suitable sites. Geological investigations were performed in three of them (1993-1994) and, later, site characterization was carried out in two candidate sites, Cernavoda and Saligny (1995-1996). In 1997, final preference was given to Saligny site, which is close to CNE Cernavoda.

In 2005, ANDR has taken over the responsibility to setup the repository and started to conclude the relevant data and information and coordinated the process that ensured the elaboration of a

technical and safety documentation that should have been support for a siting approval from CNCAN.

The work continued with more detailed characterization of the Saligny site, in order to confirm site characteristics and with the development of a pre-operational monitoring program (including development of the monitoring boreholes).

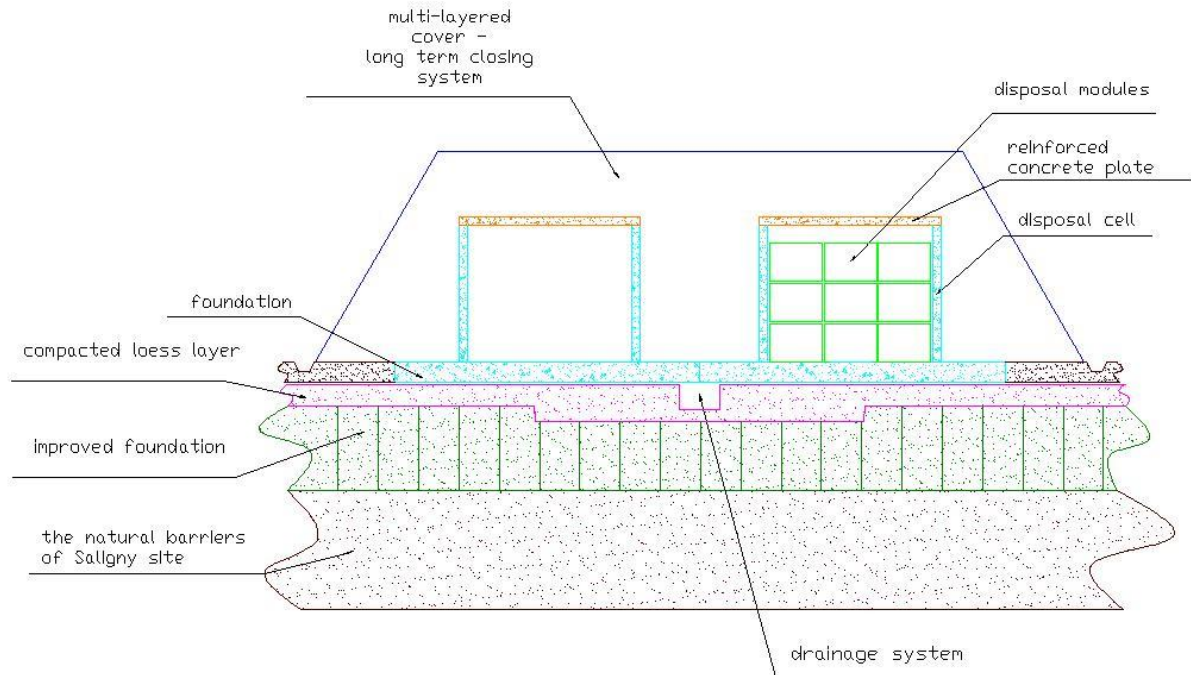

**Figure H1: A general view of the repository structures**

### ***H3.1.2. Public consultancy***

Being aware of the difficult mission to provide easy-understandable messages in the field of radioactive waste management, ANDR is carrying out an early communication program targeting both the general public and the local communities, based on openness, transparency and accountability.

During this program, a lot of activities have been performed, such as: public meetings with local people, representatives of the local authorities and NGO's; people were informed about the intended LILW near-surface repository, the characteristics of the wastes that will be disposed there, the conceptual design, as well as about the best practices in UE. Slide-shows were given; leaflets and brochures were disseminated on these occasions. The meetings had also the aim to find out which are the people's concerns related to these issues. Press conferences have been given on these issues and questions from journalists were promptly answered. Opinion surveys have been carried out in order to assess the public perception on radioactive waste and their disposal. The program is still in progress.

### ***H3.1.3 Consultancy of Contracting Parties in the vicinity of the radioactive waste management facilities***

Romania has ratified the ESPOO Convention. Consequently, any country (not only a Contracting Part), that could be affected by a radioactive waste management facility sited on Romanian territory will be announced, and will receive, upon request, the general data relating to the facility to enable it to evaluate the likely safety impact of that facility upon its territory.

### ***H3.2 Avoidance of unacceptable effects on Contracting Parties in the vicinity of the radioactive waste management facilities***

The Initial Safety Analysis, as well as the latter Preliminary Safety Analysis Report and Final Safety Analysis Report, for any new nuclear or radiological facility (not only for radioactive waste management facilities) shall prove that the national requirements, which are in line with the internationally endorsed criteria and standards, are met for individuals, society and environment, at the same level for national territory and for neighbour countries.

This requirement is obviously fulfilled for radioactive waste handling and storage facilities. Also, for surface repositories for short lived radioactive waste, it is relatively easy to demonstrate the fulfilment of the requirement.

### ***H4.Design and construction of facilities (Article 14)***

The design and construction of a radioactive waste management facility at CNE Cernavoda is part of the design and construction of the NPP. As all of the requirements of Article 14 of the Joint Convention are required by the Romanian legislation for all nuclear installations, the construction licence for a radioactive waste management facility at CNE Cernavoda is granted by CNCAN only if, inter alia:

- i.* the design and construction of the radioactive waste handling and storage system provide for suitable measures to limit possible radiological impacts on individuals, society and environment;
- ii.* at the design stage, conceptual plans and, if necessary, technical provisions for the decommissioning of radioactive waste management facility other than a disposal facility are taken into account;
- iii.* at the design stage, technical provisions for the closure of a disposal facility are prepared;
- iv.* the technologies incorporated in the design and construction of spent fuel management facility are supported by experience, testing or analysis.

It has to be mentioned that the radioactive waste management systems of CNE Cernavoda Units 1 and 2 were designed to meet adequate safety standards used in Canada and in other five countries.

According to the CNCAN Order No. 400/2005 for approval the Regulation on the general requirements for near surface repositories the following phases need licence issued by CNCAN: siting, construction, operation, closure, active institutional control. For this each steps, the regulation contains provisions for content of safety case.

Regarding the waste originated from uranium mining and milling, it has to be mentioned that the CNCAN Order No. 192/2002 for approval the Radiological safety regulations for radioactive

waste management from uranium mining and milling has a chapter with requirements related to design and construction, covering the requirements of the Joint Convention.

In conclusion, as it was previously explained, the construction licence for any radioactive waste management facility will be granted by CNCAN based on the Preliminary Safety Analysis Report, which shall demonstrate the fulfilment of the requirements of the Joint Convention presented in Article 14.

#### ***H5. Assessment of safety of facilities (Article 15)***

##### ***H5.1. Assessment of safety of future disposal facility***

According to the provisions of regulations regarding the radioactive waste near surface disposal, the following activities scheduled in pre-operational (includes site study, design, siting and construction of the repository), operational (includes operation and closure of the repository) and post-closure (includes active institutional control and passive control of the repository) stages, are licenced by CNCAN:

- a. Siting;
- b. Construction;
- c. Operation;
- d. Closure;
- e. Active institutional control.

The licensing technical support documentation for siting contains the following documents:

- a) safety assessment of the repository, developed according to the provisions of the regulations regarding the radioactive waste near surface disposal, for the siting stage, including the description of the design conceptual project of the repository;
- b) the design conceptual closure plan;
- c) the monitoring conceptual program of the environment;
- d) the synthesis of the selecting studies for the site;
- e) environmental agreement;
- f) the quality management plan;
- g) other information asked by CNCAN.

According to the above mentioned regulations, the operator of the future repository must perform a suitable comprehensive and systematic evaluation of the planned repository's safety, for the operation period and also for the post-closure period that will prove that all the safety criteria are met.

The first version of the safety assessment report was elaborated based on the safety assessment methodology from the ISAM project. The doses for the workers and the public for the reference and alternative scenarios developed for the operational period of the repository were calculated using MERCURAD computer code. The source term of the repository was calculated using DUST-MS computer code. The transport and fate of the contaminant plume in the unsaturated and saturated zones of site were evaluated using HYDRUS and PORFLOW codes, respectively. The transport and fate of the contaminants in the biosphere were assessed using RESRAD code.

The main conclusions resulted from the latest version of the Safety Assessment Report developed for the siting of the new near surface repository is that the Saligny site has the

potential to be suitable for a near surface repository because there are no obvious deficiencies in respect with the specific safety requirements.

### ***H5.2. Updated and detailed safety assessment***

According to the Romanian laws and regulations, for issuing by CNCAN of a commissioning licence for a NPP, including a radioactive waste management facility, a Final Safety Analysis Report is required, while for issuing by CNCAN of a trial operation licence or an operation licence, amended Final Safety Analysis Reports are required.

Operation requires also the issuing by the Environmental Protection Authority of an environmental authorization. This last licence is issued after starting of the operation, based on Environmental Report that includes measurements of environmental parameters.

The operating licence issued by CNCAN and the environmental authorization issued by the Environmental Protection Authority have a limited time validity and, therefore, they have to be renewed periodically. That requires the update of supporting safety and environmental assessments.

Systematic impact assessment according to internationally recognized criteria and standards are required for completion of the Environmental Impact Study and of the Environmental Report.

The Initial Safety Analysis Report, Preliminary Safety Analysis Report, Final Safety Analysis Reports and their supporting documents are containing systematic assessment of the nuclear safety and of the environmental impact, in accordance with the internationally accepted criteria and standards.

For CNE Cernavoda radioactive waste management systems, the Initial Safety Analysis Report, the Preliminary Safety Analysis Report and the Final Safety Analysis Report are realized for the whole facility.

As it was presented in the paragraphs related to articles 13 and 14, the content of Initial Safety Analysis Report and of Preliminary Safety Analysis Report for future radioactive waste management facilities shall reflect the content of IAEA requirements and guides. The same is true for the Final Safety Analysis Report.

Requirements related to the content of the radioactive waste management facilities from uranium mining and milling are included in the “Radiological Safety Regulations for Radioactive Waste Management from Uranium Mining and Milling”.

For the case of the existing radioactive waste management facilities: STDR Magurele, STDR Pitesti and LEPI Pitesti, periodical reviews of the safety assessments are required.

### ***H5.3. Assessment of safety of DNDR Baita Bihor repository***

The Final Safety Assessment Report of the Baita-Bihor repository for low and intermediate level radioactive waste has been developed and submitted to CNCAN. Based on it renewal of the operation licence has been granted.

## ***H6. Operation of facilities (Article 16)***

### ***H6.1. Licensing***

The radioactive waste management systems operated by CNE Cernavoda are nuclear power plant systems. The CNE Cernavoda operation was licensed by CNCAN following the legal procedure and based on appropriate assessment of safety. All safety analyses to support the five-formal licensing stages (site licence, construction licence, commissioning licence, trial operating licence, and operating licence) were performed for Unit 1 and Unit 2.

The trial operating licence was issued based on the amended Final Safety Analysis Report, which includes the commissioning test and control program results.

The Operating License was finally issued based on the amended Final Safety Analysis Report (Phase II), which contains amendments derived from the results and conclusions of the trial operating period. Periodically the operating license is renewed, and appropriate assessments are requested in support of the application for issuing of the new.

For any radioactive waste management facility the licence to operate the facility is based on the Final Safety Analysis Report and is conditioned on the completion of the commissioning program demonstrating that the facility, as constructed, is consistent with the design and safety requirements.

In line with the guidelines set out in the IAEA NSG.2.10, Safety Guide “Periodic Safety Review of Nuclear Power Plants”, developed in the CNCAN regulation NSN-10 “Norm for the Periodic Safety Review of Nuclear Power Plants”, at CNE Cernavoda U1 was conducted a complementary safety review - Periodic Safety Review (PSR). The development of a PSR program is a regulatory licensing condition. Further to this requirement, the discussions with the European Commission, part of the Romanian Accession negotiations for the Energy Chapter, has led to the requirement to undertake a Periodic Safety Review for the plant.

PSR is a systematic safety reassessment of the plant design and operation against current safety standards and practice that confirms a high level of safety throughout the plant’s operating lifetime. The Radioactive Waste Management programs and systems of the CNE Cernavoda units were assessed under the PSR Program, and a high level of nuclear and radiation safety in radioactive waste management and monitoring of radioactivity in effluents at CNE Cernavoda was confirmed.

### ***H6.2. Operational limits and conditions***

For operation, CNE Cernavoda issued under CNCAN approval, the reference document “Operating Policies and Principles”. This document describes how it operates, maintains and modifies the safety-related systems in order to maintain the nuclear safety margins and consequential risk to the public acceptably low. This document defines the specific operating limits for safety related systems, which must be maintained all the time to ensure that the plant always operates within its analyzed safe operating envelope. Other key boundaries for operation of radioactive waste management systems are included in their Operating Manuals.

For STDR Pitesti, LEPI Pitesti facility, STDR Magurele and DNDR Baita Bihor, technical (operational) limits and conditions are established, based on assessments, tests and operational experience. For DNDR Baita Bihor the limits and conditions include the waste acceptance criteria.

The technical limits and conditions are revised as necessary.

### ***H6.3. Operation, maintenance, monitoring, inspection and testing***

As parts of CNE Cernavoda, the radioactive waste management systems operation, maintenance, monitoring, inspection and testing activities are performed according to Station regulations: Operating Policies and Principles, Maintenance Philosophy, Quality Assurance Manual.

All these documents include, directly or by reference to appropriate procedures, rules that must be followed in performing activities related to operation, maintenance, inspection and testing.

As these documents are sustaining the operating license, the compliance with their requirements is mandatory for the NPP and any deviation must be reported to CNCAN.

As an example is presented the CNE Cernavoda radioactive waste systems monitoring program, which is part of NPP monitoring program

The Solid Radioactive Waste Interim Storage Facility monitoring program includes:

- Ground water sampling for beta-gamma and tritium activities
- Atmospheric radiation surveys including air samples and gamma dose rate at the site boundary
- Contamination surveys of the entire site and structures
- Structures watertight surveys

Status of constructions during operation is monitored as follows:

- by current observations, visualizing the general status of the three concrete structures;
- by special precision measurements on fixed points with the intent of survey the external platform and buildings status.

Similar requirements exist for LEPI and STDR Pitesti, STDR Magurele, DNDR Baita Bihor.

### ***H6.4. Engineering and technical support***

The station organization chart for CNE Cernavoda documents the general areas of responsibility. The structure of the organization considers the needs for engineering and technical supports and for this reason it includes a strong Technical Unit covering System Performance Monitoring, Design Engineering and Component Engineering.

Also, it should be mentioned that a strong link is maintained with Romanian research institutes and with designer of the plant, SNC Lavalin – Candu Energy Inc. (former Atomic Energy of Canada Limited), Romania being member of CANDU Owners Group.

ICN Pitesti and IFIN-HH consider also needs for engineering and technical supports. Their organizational chart includes also staff for operation, maintenance, monitoring, inspection and testing of radioactive waste management facilities.

### ***H6.5. Procedures for characterization and segregation of radioactive waste***



As it was presented in a previous paragraph of the section B “Policies and Practices” the radioactive waste is categorized and segregated at all radioactive waste management facilities.

The main waste producers perform the characterization and segregation of their waste according to their procedures. The characterization laboratories meet the requirement of the ISO 17025 standard.

The packages with conditioned non fuel cycle radioactive waste are characterized in order to meet the WAC for disposal at Baita Bihor repository.

Characterization consists of determination of radioactive inventory, physical and chemical properties of the waste.

#### ***H6.6. Incidents reporting to CNCAN***

Incidents significant to safety are reported in a timely manner by CNE Cernavoda to CNCAN, according to established procedures. These reports and procedures are submitted to CNCAN according to licence conditions.

Abnormal Condition Reports (ACRs) are issued by plant personnel to record and analyse those events that could have significant adverse impact on the environment, the public or the personnel safety, such as: serious process failures, violations of the Operating Policies and Principles, release of radioactive materials that exceed of targets, doses of radiation which exceed the regulatory limits, events which interfere with the IAEA safeguards system.

For each event that meets the reporting criteria to the regulator a notification is made to CNCAN immediately after the discovery of the reportable event or within one working day depending on the gravity of the event and a report is prepared to document the event. For the events that are significant or complex, more detailed reports are prepared and submitted to CNCAN within the required time period.

Similar reporting systems are established in the safety licence conditions and are documented in internal procedures of the licensee, in the case of ICN Pitesti and of IFIN-HH.

#### ***H6.7 Collection and analyzing of relevant operating experience***

For CNE Cernavoda the station goal for operating experience is to use effectively and efficiently lessons learned from other plants and station operating experience to improve plant safety and reliability.

Over the years a culture was created to report low level problems, providing the opportunity to identify representative trends based on actual plant conditions and initiate timely corrective actions to prevent degradation of performance. The increasing number of ACR is based on low-level reporting of precursor and near misses, aimed at preventing more significant consequential events, and on the continuous reinforcement of expectations for initiation of ACRs.

Station events and human performance issues often result from weaknesses or breakdowns in station processes, practices, procedures, training and system or component design that were not previously recognized or corrected. This is the reason why CNE Cernavoda considers, as the main topic of the Operating Experience Program, the Event Analysis System, comprising

identification, evaluation and analysis of operational events (both internal and external) in order to establish and implement corrective actions to avoid re-occurrence.

The external information regarding operating experience proved to be a very important tool in improving station performance. Therefore, the second main topic of the operating experience program is the Information Exchange Program, with bi-directional use:

- collecting of external information and distribution to the appropriate station personnel;
- submitting the internal operating experience information to external organizations.

The basis for Operating Experience Program was set in place since the early stage of the commissioning phase, with the objective to ensure:

- the reporting, reviewing, assessing of the station abnormal conditions and establishing of the necessary corrective actions;
- information exchange within CANDU Owner Group (COG), regarding abnormal conditions, technical problems, research and development projects, etc.

For the information exchange program, a COG (CANDU Owner Group) contact officer, appointed by the station management, with the following general responsibilities that covers the relation between CNE Cernavoda and COG:

- serve as a liaison between COG and the station;
- reviewing the incoming messages and distributing them to the appropriate plant personnel;
- ensure the transmittal of the required information/reports to COG;
- ensure optimum participation of the station personnel to share plant events.

Programs to collect and analyse relevant operating experience are in place also at ICN Pitesti and IFIN-HH.

### ***H6.8 Decommissioning plans for radioactive waste management facilities***

According to the provisions of Law no.111/1996 any nuclear installation needs to prepare decommissioning plans. This is valid also for the radioactive management facilities, other than repository. The regulations for decommissioning of nuclear facilities and installations require that for any radioactive waste treatment and conditioning facility, as well as for any radioactive waste storage facility, decommissioning plans shall be prepared and updated.

CNE Cernavoda has elaborated and submitted to CNCAN, for approval, the following documents:

- K-414716-00001 - SNN Cernavoda NPP Units 1&2 Preliminary Decommissioning Plan;
- K-414716-00003 - SNN Cernavoda NPP Units 1&2 Decommissioning Costing Report.

Planning for the decommissioning of CNE Cernavoda Units 1&2 is an ongoing process. The documents above will be reviewed and updated, as needed, prior to license renewals and/or at intervals determined by the regulations (*Law no. 111/1996*).

### ***H6.9. Plans for closure of disposal facilities***

According to the CNCAN Order No. 400/2005 for approval the Regulation on the general requirements for near surface repositories, the closure of a near surface repository needs licence for CNCAN. The Preliminary Safety Analysis report as well as the Final Safety Report of

DNDR Baita Bihor contains a special chapter which refers to the closure of repository. IFIN-HH is in the process of developing a closure strategy of DNDR Baita Bihor, in collaboration with RATEN-CITON and University of Civil Engineering from Bucharest, which is assumed to be submitted to CNCAN in the first part of 2018.

The CNCAN Order No. 192/2002 for approval the Radiological safety regulation for radioactive waste management from uranium mining and milling has provisions regarding the closure of the waste management facilities for uranium mining and milling.

***H7. Institutional measures after closure (Article 17)***

According to the CNCAN Order No. 400/2005 for approval the Regulation on the general requirements for near surface repositories, the active institutional control needs a licence from CNCAN. The regulation contains provisions on the institutional control after closure of repository. In the safety assessment report of DNDR Baita Bihor there is a chapter which details the monitoring after closure of repository.

It has to be mentioned that for the uranium mining and milling repositories, such requirements are implemented by the CNCAN Order No. 192/2002 for approval the Radiological safety regulations for radioactive waste management from uranium mining and milling.

## **SECTION I.      TRANSBOUNDARY MOVEMENT (*Article 27*)**

### ***II. Steps to transboundary movements***

#### ***II.1 Licensing of transboundary movement***

According to Law no. 111/1996, the import, export, and intercommunity transfer of radioactive materials, including spent fuel and radioactive waste, shall be licensed by CNCAN. It shall be noted that according to the above mentioned law, the import of radioactive waste is prohibited. The only exception is when the import follows directly from the processing outside Romanian territory, of a previously licensed export of radioactive waste, on the basis of the provisions of international agreements or of contracts concluded with commercial partners, under the terms of Law no. 111/1996.

According to the Romanian regulations for transport of radioactive materials the international shipment of radioactive materials can be performed only if the carrier gets a transport licence issued by CNCAN. The shipments of B(U), B(M), C packages as well as any shipment of fissile materials, which is not excepted by regulations, needs a shipment licence issued for the carrier or consignor for that particular shipment. The international shipments of any other packages or materials need to be notified to CNCAN before entering on the Romanian territory.

The shipment of radioactive waste and spent nuclear fuel is performed according to the 2006/117/EURATOM Council Directive on the supervision and control of shipments of radioactive waste and spent nuclear fuel which was transposed and fully implement into Romanian legislation.

Council Directive 2006/117/EURATOM was transposed by the CNCAN Order No. 443/2008 for approval the Regulation on the supervision and control of shipments of radioactive waste and spent nuclear fuel on the Romanian territory.

In the scope of application of the Council Directive the standard document as it was established by Commission Decision of 5 March 2008 establishing the standard document for the supervision and control of shipments of radioactive waste and spent fuel is used.

Also, the provision of the Commission Recommendation of 7 July 2009 for a secure and effective system of transmission of documents and information relating to the provisions of Council Directive 2006/117/EURATOM are used.

For shipment of radioactive sources the Council Regulation 1493/1993 on the international shipment of radioactive materials between Member States is implemented into Romanian legislation. This regulation regulates the movement of radioactive sources between countries of European Union. The movement of radioactive sources is based on the consensus of destination country and it is done using a shipment declaration. The import/export of radioactive sources to/from European Union countries shall be licensed by CNCAN.

#### ***II.2. Subject of transit to relevant international obligations***

Romania has been ratified and implemented the provisions of international agreements and conventions regarding the transport of dangerous goods (ADR, AND, RID, ICAO).

As it was explained above, all international shipments of spent fuel/radioactive waste involving Romanian territory need to be licensed by CNCAN.

In the licensing process, conditions are stated for presenting all the authorizations of the countries involved in the shipment and for harmonization of emergency plans and of escort arrangements of the countries involved in transport of spent fuel.

### ***11.3. Consent of transboundary movement by the State of destination***

Romania authorizes only shipments for which it is obtained the consent by destination country.

### ***11.4. Licensing of transboundary movement***

When all requirements are met, Romania grants a single licence which may cover more than one shipment of radioactive waste and spent nuclear fuel. Any licence will be valid for a period of not more than three years.

Licences can cover both intra-community and extra-community shipments as well as transit through Community.

For licensing and communication with other authorities, Romania uses the standard document as it is required by Council Directive as well as Commission Decision on the establishing the standard document for the supervision and control of shipments of radioactive waste and spent fuel.

### ***11.5. Re-entry into the Romanian territory***

In case the transboundary movement is not or cannot be completed in accordance with safety requirements, re-entry into the Romanian territory CNCAN shall ensure that the radioactive waste or the spent fuel in question is taken back by the holder, unless an alternative safe arrangement can be made. CNCAN shall ensure that the person responsible for the shipment takes corrective safety measures where necessary. In this case the holder shall be liable for costs arising in cases where the shipment cannot or may not be completed.

## ***12. Shipment of spent fuel or radioactive waste to a destination south to latitude 60° south for storage or disposal***

According to the provisions of the Regulations for International Shipments of Radioactive Wastes Involving Romanian Territory, CNCAN shall not authorize radioactive waste shipments:

- to a destination south of latitude 60° south; or
- to a State which is party to the Partnership Agreement between the members of the African, Caribbean and Pacific Group of States of the one part, and the European Community and its Member States, of the other part, (Cotonou ACP-EC Agreement) which is not a Member State, without prejudice to Article 2, or
- to a third country which does not, in the opinion of the competent authorities of the Member State of origin, have the administrative and technical capacity and regulatory structure to manage the radioactive waste or spent fuel safely, as stated in the Joint Convention.

In order to assess the above requirements it is used the criteria for the export of radioactive waste and spent nuclear fuel to the third countries as they are mentioned into Commission Recommendation.

### ***13. Rights of contracting parties***

As presented before, Romania has a legislative framework in accordance with international agreements and recommendations.

*i.* The Romanian transport regulations do not affect the exercise by ships and aircrafts of foreign countries, of maritime, river and air navigation rights and freedoms, as provided by international law.

*ii.* As presented above, import of radioactive waste shall be allowed, when the import follows directly from the processing outside Romanian territory, of a previously authorized export of radioactive waste, on the basis of the provisions of international agreements or of contracts concluded with commercial partners, under the terms of Law no. 111/1996.

*iii.* The Law no. 111/1996 establishes that the export of spent fuel for reprocessing is allowed.

*iv.* If export of spent fuel for reprocessing will be performed, the radioactive waste and other products resulting from reprocessing will be allowed to be returned, according to the provisions of the Law no. 111/1996 presented above, if there will be not arrangements for keeping the waste in the country where the fuel is reprocessed .

## **SECTION J.      DISUSED SEALED SOURCES (*Article 28*)**

### ***J1. Safe possession, remanufacturing or disposal of disused sealed sources***

According to Romanian regulations, the radiation practices, including those involving sealed sources, shall be licensed. Exempted practices involve very low activity sources in consumer products, e. g.  $^{241}\text{Am}$  smoke detectors of 1  $\mu\text{Ci}$ . According to Fundamental Regulations on Radiological Safety even these exempted radioactive sources are required to be disposed as radioactive waste.

The licensing of a practice does include the list of radiological installations, and the list of sealed sources contained in these installations. The transfer of radiological installations and radioactive sources from one licence holder to other holder requires transfer licence.

The transfer of sources for treatment, conditioning and long term storage or disposal is based on notification to CNCAN and it is performed without transfer licence. In this case, the sources are transferred to STDR Magurele. STDR Magurele has procedures for receiving the sources and for keeping records. The licensee shall support the payment for the return to producer or for transfer to STDR Magurele.

Generally, CNCAN requires that the sources that are no longer used, be transferred to STDR Magurele, or to another user, if they are still able to be used.

The storage of the disused sources is inspected by CNCAN, and if the conditions are not acceptable, CNCAN can take actions to enforce observance of regulations.

CNCAN develops and maintains a sealed radioactive source tracking system and it is responsible to manage the National Source Register.

### ***J2. Re-entry into the Romanian territory of disused sealed sources***

As presented before, according to Law no. 111/1996, Romania does not allow the import of radioactive waste, i.e. re-entry on Romanian territory of disused sealed sources is not allowed, except in the case that the source can be reused.

## **SECTION K. PLANNED ACTIVITIES TO IMPROVE SAFETY OF SPENT FUEL AND RADIOACTIVE WASTE MANAGEMENT**

In order to improve the safety the following issues are identified as important for Romania for the next period:

1. Approval by the Romanian Government of the updated version of the National Strategy on medium and long term safe management of the spent nuclear fuel and radioactive waste, which is now subject of SEA procedure.
2. Getting the siting license for the new near-surface LILW repository.
3. Maintaining an updated database on the National Radioactive Waste Inventory.
4. Development of a preliminary programme for establishing a geological repository.
5. Updating the financial contribution of the waste generators to the funds earmarked for radioactive waste management and for the decommission activities, based on the recently updated costs for the disposal facilities and the decommission activities.
6. Commissioning of the Experimental Pilot Installation for Separation of Deuterium and Tritium at ICSI Rm.Valcea.
7. Construction and commissioning of Cernavoda Tritium Removal Facility.
8. Implementation of an improved MACSTOR 400 modules in order to increase the spent fuel storage capacity.
9. Closure of the first part of Cetatuaia II tailing pond of the Uranium Milling Plant of the Feldioara Subsidiary of the National Uranium Company.
10. Continuation of rehabilitation of the sites with sterile rock and low radioactive rock dumps resulted from geological research and mining activities for uranium ores production within the National Uranium Company.
11. Continuation of decommissioning activities of VVR-S research reactor by IFIN-HH, Magurele.



## SECTION L. ANNEXES

### Annex L-1: List of Spent Fuel Management Facilities

Licensee – Site Name	Facility Name	Main purpose
<b>Nuclear Power Plant</b>		
SNN/CNE – Cernavoda	The Spent Fuel Handling System – U1	Wet handling and storage of the CANDU spent and failed nuclear fuel bundles
	The Spent Fuel Handling System – U2	
	The Interim Spent Fuel Dry Storage Facility (DICA)	Dry storage of the CANDU spent nuclear fuel bundles
<b>Institute for Nuclear Research</b>		
RATEN/ICN – Pitesti	The Spent Fuel Storage Pool	Wet storage of the TRIGA spent nuclear fuel elements (LEU)
	The Dry Storage Pits	Dry storage of the irradiated experimental nuclear fuel elements and fragments (TRIGA and CANDU)

***Annex L-3: List of Radioactive Waste Management Facilities***

Licensee – Site Name	Facility Name	Main purpose
<b>Nuclear Power Plant</b>		
SNN/CNE – Cernavoda	The Solid Radioactive Waste System	Pretreatment and storage of NPP solid operational waste, except spent resins
	The Organic Liquid Radioactive Handling System	Organic liquid pretreatment and storage
	The Spent Resins Handling System	Storage of NPP spent resins
	The Gaseous Radioactive Waste System	Gaseous filtering and airborne releasing
	The Aqueous Liquid Radioactive Waste System	Aqueous liquid decontamination and environment discharging

**Nuclear Fuel Plant**

SNN/FCN Pitesti	The Gaseous Radioactive Waste System	Gaseous filtering and airborne releasing
	The Liquid Radioactive Waste Temporary Storage Tanks	Storage of liquid waste and liquid effluents
	The Platform for Temporary Storage of Solid Radioactive Waste	Storage of solid radioactive waste contaminated (only natural uranium) There are two category: combustible non-combustible

**Nuclear Research Institutes**

RATEN/ICN– Pitesti	Radioactive Waste treatment Plant (STDR Pitesti)	Treatment and conditioning of waste generated at ICN Pitesti and FCN Pitesti
		Recovery of Uranium from waste generated at FCN Pitesti
	Post Irradiation Examination Facility (LEPI)	Storage of HLW and LILW-LL
IFIN-HH – Magurele	Radioactive Waste Treatment Plant (STDR Magurele)	Treatment, conditioning and storage of non fuel cycle radioactive waste
IFIN-HH – Baita- Bihor	National Repository for Low and Intermediate Level Waste (DNDR)	Disposal of the non fuel cycle radioactive waste

**Uranium Mining and Milling**

CNU – Feldioara	Cetățuia II Tailing Pond – Part 1	Settling and storing of radioactive tailings resulted from milling process
	Cetățuia II Tailing Pond – Part 2	
	Mittelzop Tailing Pond	Final settling of fines tailings
	The Old Trench Type Storage Facilities	Storage of low activity solid waste
	The Low Activity Solid Radioactive Waste Storage Facility - Part 1	
The Low Activity Solid Radioactive Waste Storage Facility - Part 2		
CNU – Suceava	Various mining and research sites	Storage and environment restoration/ remediation of sterile and radioactive rocks dumps resulted from research and uranium mining activities
CNU – Stei (Bihor)		
CNU – Oravita (Banat)		

### **Annex L-6: List of regulations**

#### *Laws:*

- Law no.111/1996 on the safe deployment, regulation, authorization and control of nuclear activities, republished with subsequent completion and modification
- Law no.105/1999 on the ratification of Joint Convention on the safe management of nuclear fuel and on the safe management of radioactive waste
- Government Ordinance no. 195/2005 on environmental protection
- Law no. 481/2004 on civil protection
- Law no. 43/1995 on ratification of Nuclear Safety Convention
- Law no. 703/2001 on civil liability for nuclear damages
- Governmental Ordinance no. 11/2003 regarding the management of nuclear spent fuel and radioactive waste, including their disposal, with subsequent modifications and completions
- Governmental Ordinance no. 7/2003 regarding the use of nuclear energy in exclusive peaceful purposes, with subsequent modifications and completions
- Law no. 15/2005 for approval of Governmental Ordinance no. 21/2004 on national system of emergency situations management.

#### *Fundamental regulations on radiological safety:*

- CNCAN Order No. 14/2000 for approval of the Radiological Safety Fundamental Regulations; this regulation transposed the Council Directive 96/29/EURATOM of 13 May 1996 laying down basic safety standards for the protection of the health of workers and the general public against the dangers arising from ionizing radiation.
- Order no. 381/2004 of Health Minister for approval of Fundamental sanitary regulations on the safe deployment of nuclear activities.
- CNCAN Order No. 56/2004 for approval the Fundamental regulations on the safe management of radioactive waste and spent nuclear fuel, republished.

#### *Specific regulations:*

- CNCAN Order No. 115/2017 for approval the Regulation on the specific requirements for decommissioning of nuclear and radiological facilities
- CNCAN Order No. 148/2017 for approval the Regulation on the safety requirements for the predisposal activities of radioactive waste, disused radioactive sources and spent nuclear fuel
- CNCAN Order No. 374/2016 for approval the Nuclear safety regulation on the ageing management for nuclear facilities
- CNCAN Order No. 132/2017 for approval the Nuclear safety regulation on the events recording, reporting and analysing and using of the operating experience for the nuclear facilities
- CNCAN Order No. 177/2015 for approval the Regulation on the nuclear safety policy and independent review of nuclear facilities
- CNCAN Order No. 114/2017 for approval the Fundamental regulation on the nuclear safety
- CNCAN Order No. 143/2017 for approval the Guide on content and format of safety assessment report for research reactors

- CNCAN Order No. 142/2017 for approval the Guide on content and format of safety assessment report for fuel fabrication plants
- CNCAN Order No. 108/2017 for approval the Regulation on training, qualification and licensing of staff who operates nuclear facilities
- CNCAN Order No. 69/2014 for approval the Regulation on the requirements for planning and response to nuclear and radiological emergency
- CNCAN Order No. 61/2014 for approval the Regulation on granting the exercising permits for operator staff, management staff and those with special training from nuclear power plants, research reactors and other nuclear facilities.
- CNCAN Order No. 334/2010 for approval the Regulation on the safety requirements for siting of nuclear power plants
- CNCAN Order No. 335/2010 for approval the Regulation on the safety requirements for design and construction of nuclear power plants
- CNCAN Order No. 89/2010 for approval the Regulation on the radiological monitoring of scrap metal during collection, trade and processing
- CNCAN Order No. 443/2008 for approval the Regulation on the supervision and control of shipments of radioactive waste and spent nuclear fuel on the Romanian territory;
- CNCAN Order No. 62/2004 for approval the Regulation on the removal from regulatory control of materials from nuclear activities
- CNCAN Order No. 156/2005 for approval the Regulation on the classification of radioactive waste
- CNCAN Order No. 400/2005 for approval the Regulation on general requirements for near surface disposal
- CNCAN Order No. 221/2005 for approval the Regulation on limiting of effluents release
- CNCAN Order No. 127/2002 for approval the Radiological safety regulation on operational radiation protection in mining and milling of uranium and thorium ores
- CNCAN Order No. 192/2002 for approval the Radiological safety regulation on management of radioactive waste from mining and milling of uranium and thorium ores
- CNCAN Order No. 207/2003 for approval the Radiological safety regulation on decommissioning of installations of mining and/or processing of uranium and thorium ores - Criteria for release from licensing regime, for use for other purposes of buildings, materials, installations, dumps and lands contaminated from the activities of mining and/or processing of uranium and thorium ores
- CNCAN Order No. 184/2006 for approval the Regulations for decommissioning of uranium and thorium mining and milling facilities
- CNCAN Order No. 353/2001 for approval the Radiological safety regulation of operational radiation protection of outside workers
- CNCAN Order No. 228/16.12.2002 for approval the Radiological safety regulation - Acceptance procedures for external undertakings
- CNCAN Order No. 363/2001 for approval the Regulation on safeguards in nuclear field
- CNCAN Order No. 382/2001 for approval the Regulation on physical protection in nuclear field
- CNCAN Order No. 366/2001 for approval the Radiological safety regulation - Licensing procedures
- CNCAN Order No. 73/2002 for approval the Regulation for licensing of use of radiation sources outside protected areas
- CNCAN Order No. 274/06.08.2004 for approval the Regulation for notified bodies in nuclear field

- CNCAN Order No. 356/2005 for approval the Regulation for high activity sources and orphan sources
- CNCAN Order No. 421/2004 for approval the Regulation on delivering and using the individual radiation protection equipment
- CNCAN Order No. 106/2002 for approval the Regulation on the requirements for guards and security personnel qualification
- CNCAN Order No. 180/2002 for approval the Regulation on individual dosimetric monitoring, with subsequent completion and modification
- CNCAN Order No. 202/2002 for approval the Regulation on issuing of exercising permits for nuclear activities and accreditation of the radiation protection qualified experts
- CNCAN Order No. 65/2003 for approval the Regulation on authorization of the quality management systems applied to the setting-up, operation and decommissioning of nuclear installations
- CNCAN Order No. 66/2003 for approval the Regulation on general requirements for the quality management system applied to the setting-up, operation and decommissioning of nuclear installations, with subsequent modification and completion
- CNCAN Order No. 67/2003 for approval the Regulation on specific requirements for the quality management systems applied to the evaluation and selection of the nuclear installations sites
- CNCAN Order No. 68/2003 for approval the Regulation on specific requirements for the quality management systems applied to the research-development activities in nuclear field
- CNCAN Order No. 69/2003 for approval the Regulation on specific requirements for the quality management systems applied to the design of nuclear installations
- CNCAN Order No. 70/2003 for approval the Regulation on specific requirements for the quality management systems applied to supplies activities dedicated to nuclear installations
- CNCAN Order No. 71/2003 of CNCAN for approval the Regulation on specific requirements for the quality management systems applied to the manufacturing activities of products and providing services dedicated to nuclear installations
- CNCAN Order No. 72/2003 for approval the Regulation on specific requirements for the quality management systems applied to the constructions and assembling activities dedicated to nuclear installations
- CNCAN Order No. 73/2003 for approval the Regulation on specific requirements for the quality management systems applied to commissioning activities of nuclear installations
- CNCAN Order No. 74/2003 for approval the Regulation on specific requirements for the quality management systems applied to the operation of nuclear installations
- CNCAN Order No. 75/2003 for approval the Regulation on specific requirements for the quality management systems applied to the decommissioning activities of nuclear installations
- CNCAN Order No. 76/2003 for approval the Regulation on specific requirements for the quality management systems applied to the “software” used in the scientific and design activities dedicated to nuclear installations
- CNCAN Order No. 213/2006 for approval the Guide on the technical requirements for design, siting, construction, operation, closure and decommissioning for storage facilities of uranium and thorium ores and of the waste resulted from milling of uranium and thorium ores
- CNCAN Order No. 407/2005 for approval the Regulation on the construction licensing in the nuclear field

- CNCAN Order No. 275/2005 for approval the Regulation on the monitoring of environmental radioactivity around nuclear and radiological facilities
- CNCAN Order No. 276/2005 for approval the Regulation on the monitoring of releases from nuclear and radiological facilities
- CNCAN Order No. 303/2007 for approval the Guide on the physical protection during transport of radioactive materials
- CNCAN Order No. 357/2005 for approval the Regulation on the transport of radioactive materials
- CNCAN Order No. 274/2005 for approval the Regulation on the supervising and control of international shipments of radioactive waste involving Romanian territory
- CNCAN Order No. 329/2006 for approval the Instructions for application of Council Regulation no. 1493/93 on the international shipment of radioactive substances between Member States
- CNCAN Order No. 141/2006 for approval the Regulation on the fire protection of nuclear power plants
- CNCAN Order No. 316/2006 for approval the Regulation on the probabilistic safety assessment for nuclear power plants
- CNCAN Order No. 135/2006 for approval the Regulation on the periodic safety review for nuclear power plants
- Republican nuclear safety regulations for nuclear reactors and nuclear power plants /1975
- Regulations for prevention and extinguishing of fire and for providing vehicles, installations, devices, apparatus, protection equipment and chemical substances for preventing and extinguishing of fires in nuclear field / 1978.